

RAM PROMASTER

2016 USER GUIDE



RAM

PROMASTER

2016 USER GUIDE

If you are the first registered retail owner of your vehicle, you may obtain a complimentary printed copy of the Owner's Manual, Navigation/Uconnect Manuals or Warranty Booklet by calling 1-866-726-4636 (U.S.) or 1-800-387-1143 (Canada) or by contacting your dealer.

IMPORTANT

This User Guide is intended to familiarize you with the important features of your vehicle. The DVD enclosed contains your Owner's Manual, Navigation/Uconnect Manuals, Warranty Booklets, Tire Warranty and Roadside Assistance (new vehicles purchased in the U.S.) or Roadside Assistance (new vehicles purchased in Canada) in electronic format. We hope you find it useful. U.S. residents can purchase replacement DVD kits by visiting www.techauthority.com and Canadian residents can purchase replacement DVD kits by calling 1-800-387-1143.

The driver's primary responsibility is the safe operation of the vehicle. Driving while distracted can result in loss of vehicle control, resulting in a collision and personal injury. FCA US LLC strongly recommends that the driver use extreme caution when using any device or feature that may take their attention off the road. Use of any electrical devices, such as cellular telephones, computers, portable radios, vehicle navigation or other devices, by the driver while the vehicle is moving is dangerous and could lead to a serious collision. Texting while driving is also dangerous and should never be done while the vehicle is moving. If you find yourself unable to devote your full attention to vehicle operation, pull off the road to a safe location and stop your vehicle. Some states or provinces prohibit the use of cellular telephones or texting while driving. It is always the driver's responsibility to comply with all local laws.

TABLE OF CONTENTS

INTRODUCTION/WELCOME

WELCOME FROM FCA US LLC	2
-------------------------	---

CONTROLS AT A GLANCE

DRIVER COCKPIT	4
INSTRUMENT CLUSTER	6

GETTING STARTED

KEY FOB	8
SEAT BELT SYSTEMS	8
SUPPLEMENTAL RESTRAINT SYSTEM (SRS) — AIR BAGS	9
CHILD RESTRAINTS	14
HEAD RESTRAINTS	16
FRONT SEATS	17
HEATED SEATS	22
TELESCOPING STEERING COLUMN	23

OPERATING YOUR VEHICLE

ENGINE BREAK-IN RECOMMENDATIONS	24
MANUAL CLIMATE CONTROLS	25
MULTIFUNCTION LEVER	26
INTERIOR LIGHTS	27
WINDSHIELD WIPERS AND WASHERS	29
ELECTRONIC SPEED CONTROL	31
PARKSENSE REAR PARK ASSIST	34
PARKVIEW REAR BACK-UP CAMERA	35

ELECTRONICS

YOUR VEHICLE'S SOUND SYSTEM	36
CYBERSECURITY	38
IDENTIFYING YOUR RADIO	39
UCONNECT RH3	40
UCONNECT 5.0	42
UCONNECT 5.0 VOICE RECOGNITION QUICK TIPS	47
UCONNECT PHONE	54
STEERING WHEEL AUDIO CONTROLS	63
ELECTRONIC VEHICLE INFORMATION CENTER (EVIC)	63
PROGRAMMABLE FEATURES	64
POWER OUTLETS	64

UTILITY

TRAILER TOWING WEIGHTS (MAXIMUM TRAILER WEIGHT RATINGS)	66
RECREATIONAL TOWING (BEHIND MOTORHOME, ETC.)	66

DIESEL

DIESEL ENGINE BREAK-IN RECOMMENDATIONS	68
DIESEL ENGINE STARTING PROCEDURES	68
AUTOMATED MANUAL TRANSMISSION — DIESEL ONLY	70
EXHAUST REGENERATION	74

COOL-DOWN IDLE CHART	76
ADDING FUEL	76
DIESEL EXHAUST FLUID	77

WHAT TO DO IN EMERGENCIES

ROADSIDE ASSISTANCE	80
INSTRUMENT CLUSTER WARNING LIGHTS	80
INSTRUMENT CLUSTER INDICATOR LIGHTS	84
IF YOUR ENGINE OVERHEATS	86
JACKING AND TIRE CHANGING	87
JUMP-STARTING PROCEDURES	102
GEAR SELECTOR OVERRIDE	106
TOWING A DISABLED VEHICLE	106
FREEDING A STUCK VEHICLE	107
ENHANCED ACCIDENT RESPONSE SYSTEM (EARS)	108
EVENT DATA RECORDER (EDR)	108

MAINTAINING YOUR VEHICLE

TO OPEN AND CLOSE THE HOOD	109
ENGINE COMPARTMENT — 3.6L	110
ENGINE COMPARTMENT — 3.0L DIESEL	112
FLUID CAPACITIES — GASOLINE ENGINE	114
FLUIDS, LUBRICANTS AND GENUINE PARTS — GASOLINE ENGINE	114
FLUID CAPACITIES — DIESEL ENGINE	115
FLUIDS, LUBRICANTS AND GENUINE PARTS — DIESEL ENGINE	116
MAINTENANCE PROCEDURES	118
MAINTENANCE SCHEDULE — GASOLINE ENGINE	118
MAINTENANCE SCHEDULE — DIESEL ENGINE	123
FUSES	128
TIRES — GENERAL INFORMATION	131
REPLACEMENT BULBS	134

CUSTOMER ASSISTANCE

FCA US LLC CUSTOMER CENTER	135
FCA CANADA INC. CUSTOMER CENTER	135
ASSISTANCE FOR THE HEARING IMPAIRED	135
PUBLICATIONS ORDERING	135
REPORTING SAFETY DEFECTS IN THE UNITED STATES	136

MOPAR® ACCESSORIES

AUTHENTIC ACCESSORIES BY MOPAR	137
--------------------------------	-----

FAQ's

FREQUENTLY ASKED QUESTIONS	138
----------------------------	-----

INDEX	139
-------	-----

INTRODUCTION/WELCOME

WELCOME FROM FCA US LLC

Congratulations on selecting your new FCA US LLC ("FCA US") vehicle. Be assured that it represents precision workmanship, distinctive styling, and high quality - all essentials that are traditional to our vehicles.

Your new FCA US vehicle has characteristics to enhance the driver's control under some driving conditions. These are to assist the driver and are never a substitute for attentive driving. They can never take the driver's place. Always drive carefully.

Your new vehicle has many features for the comfort and convenience of you and your passengers. Some of these should not be used when driving because they take your eyes from the road or your attention from driving. Never text while driving or take your eyes more than momentarily off the road.

This guide illustrates and describes the operation of features and equipment that are either standard or optional on this vehicle. This guide may also include a description of features and equipment that are no longer available or were not ordered on this vehicle. Please disregard any features and equipment described in this guide that are not available on this vehicle. FCA US reserves the right to make changes in design and specifications and/or make additions to or improvements to its products without imposing any obligation upon itself to install them on products previously manufactured.

This User Guide has been prepared to help you quickly become acquainted with the important features of your vehicle. It contains most things you will need to operate and maintain the vehicle, including emergency information.

The DVD includes a computer application containing detailed owner's information which can be viewed on a personal computer or MAC computer. The multimedia DVD also includes videos which can be played on any standard DVD player (including the Uconnect Touchscreen Radios if equipped with DVD player capabilities). Additional DVD operational information is located on the back of the DVD sleeve.

For complete owner information, refer to your Owner's Manual on the DVD in the owner's kit provided at the time of new vehicle purchase. For your convenience, the information contained on the DVD may also be printed and saved for future reference.

FCA US is committed to protecting our environment and natural resources. By converting from paper to electronic delivery for the majority of the user information for your vehicle, together we greatly reduce the demand for tree-based products and lessen the stress on our environment.

INTRODUCTION/WELCOME

VEHICLES SOLD IN CANADA

With respect to any vehicles sold in Canada, the name FCA US LLC shall be deemed to be deleted and the name FCA Canada Inc. used in substitution (excluding legal lines).

WARNING!

- Pedals that cannot move freely can cause loss of vehicle control and increase the risk of serious personal injury.
- Always make sure that objects cannot fall into the driver foot well while the vehicle is moving. Objects can become trapped under the brake pedal and accelerator pedal causing a loss of vehicle control.
- Failure to properly follow floor mat installation or mounting can cause interference with the brake pedal and accelerator pedal operation causing loss of control of the vehicle.
- Never leave children alone in a vehicle, or with access to an unlocked vehicle. Allowing children to be in a vehicle unattended is dangerous for a number of reasons. A child or others could be seriously or fatally injured. Children should be warned not to touch the parking brake, brake pedal or the transmission gear selector.
- Do not leave the key fob in or near the vehicle, or in a location accessible to children. A child could operate power windows, other controls, or move the vehicle.
- Never use the 'PARK' position as a substitute for the parking brake. Always apply the parking brake fully when parked to guard against vehicle movement and possible injury or damage.
- Refer to your Owner's Manual on the DVD for further details.

USE OF AFTERMARKET PRODUCTS (ELECTRONICS)

The use of aftermarket devices including cell phones, MP3 players, GPS systems, or chargers may affect the performance of on-board wireless features. If you are experiencing difficulties with any of your wireless features, try disconnecting your aftermarket devices to see if the situation improves. If your symptoms persist, please see an authorized dealer.

When it comes to service, remember that your authorized dealer knows your vehicle best, has factory-trained technicians and genuine MOPAR® parts, and cares about your satisfaction.



CONTROLS AT A GLANCE



DRIVER COCKPIT

1. Power Mirrors
2. Headlight Switch pg. 26
3. Instrument Cluster/Electronic Vehicle Information Center (EVIC) Display pg. 6
4. Windshield Washer Operation pg. 30
5. Transmission Shifter
6. Audio System (Touchscreen Radio Shown) pg. 36
7. Clip Board
8. Climate Controls pg. 25
9. Storage
10. Power Window Switch
11. Glove Compartment

CONTROLS AT A GLANCE

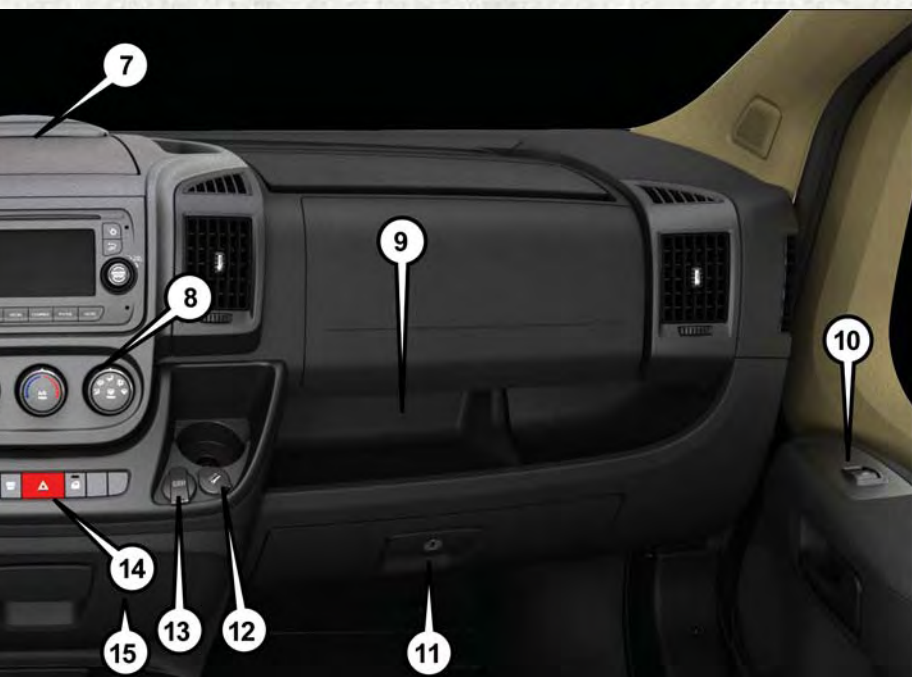

12. Power Outlet pg. 64
13. USB Port (Charging Only)
14. Switch Panel
 - Front Fog Lights
 - Electronic Stability Control (ESC) OFF pg. 85
 - Hazard Warning Switch
 - Central Door Lock Switch
15. Storage — If Equipped
16. USB Port
17. Ignition Switch
18. Uconnect Phone Controls pg. 54
19. Uconnect Phone Controls pg. 54
20. Speed Control pg. 31
21. Hood Release pg. 109
22. Power Windows

CONTROLS AT A GLANCE

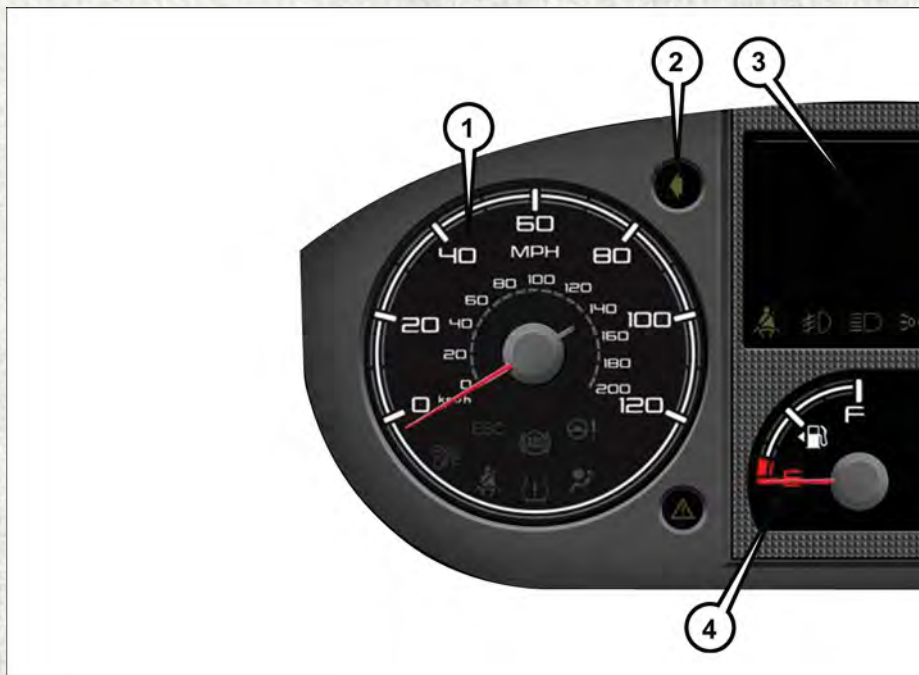

INSTRUMENT CLUSTER

1. Speedometer
2. Turn Signal Lights
3. Electronic Vehicle Information Center (EVIC)
4. Fuel Gauge

(See page 80 for Instrument Cluster Warning Lights.)

CONTROLS AT A GLANCE



- 5. Turn Signal Lights
- 6. Tachometer
- 7. Temperature Gauge

(See page 84 for Instrument Cluster Indicator Lights.)

GETTING STARTED

KEY FOB

Locking And Unlocking The Doors

- Push the LOCK button once to lock all the doors.
- Push the UNLOCK button once to unlock the driver's door only and twice within five seconds to unlock the passenger door.

All doors can be programmed to unlock on the first press of the UNLOCK button. Refer to "Uconnect Settings" in "Understanding Your Instrument Panel" in the Owner's Manual on your DVD for further information.

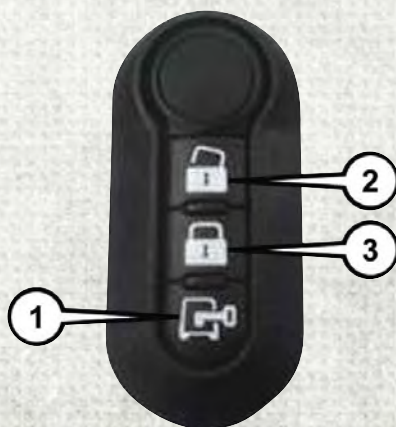

Key Fob

- 1 — Cargo Doors
- 2 — Unlock
- 3 — Lock

SEAT BELT SYSTEMS

Lap/Shoulder Belts

All seating positions in your vehicle are equipped with lap/shoulder belts.

Be sure everyone in your vehicle is in a seat and using a seat belt properly.

Position the lap belt so that it is snug and lies low across your hips, below your abdomen. To remove slack in the lap belt portion, pull up on the shoulder belt. To loosen the lap belt if it is too tight, tilt the latch plate and pull on the lap belt. A snug seat belt reduces the risk of sliding under the seat belt in a collision.

Position the shoulder belt across the shoulder and chest with minimal, if any slack so that it is comfortable and not resting on your neck. The retractor will withdraw any slack in the shoulder belt.

Seat Belt Pretensioner

The front seat belt system is equipped with pretensioning devices that are designed to remove slack from the seat belt in the event of a collision.

A deployed pretensioner or a deployed air bag must be replaced immediately.

WARNING!

- In a collision, you and your passengers can suffer much greater injuries if you are not properly buckled up. You can strike the interior of your vehicle or other passengers, or you can be thrown out of the vehicle. Always be sure you and others in your vehicle are buckled up properly.
- A shoulder belt placed behind you will not protect you from injury during a collision. You are more likely to hit your head in a collision if you do not wear your shoulder belt. The lap and shoulder belt are meant to be used together.
- A seat belt that is too loose will not protect you properly. In a sudden stop, you could move too far forward, increasing the possibility of injury. Wear your seat belt snugly.
- A frayed or torn seat belt could rip apart in a collision and leave you with no protection. Inspect the seat belt system periodically, checking for cuts, frays, or loose parts. Damaged parts must be replaced immediately. Do not disassemble or modify the system. Seat belt assemblies must be replaced after a collision.

SUPPLEMENTAL RESTRAINT SYSTEM (SRS) — AIR BAGS

Air Bag System Components

Your vehicle may be equipped with the following air bag system components:

- Occupant Restraint Controller (ORC)
- Air Bag Warning Light 
- Steering Wheel and Column
- Instrument Panel
- Knee Impact Bolsters
- Advanced Front Air Bags
- Supplemental Side Air Bags
- Front and Side Impact Sensors
- Seat Belt Pretensioners
- Seat Belt Buckle Switch
- Seat Track Position Sensors

GETTING STARTED

Advanced Front Air Bags

This vehicle has Advanced Front Air Bags for both the driver and front passenger as a supplement to the seat belt restraint systems. The Advanced Front Air Bags will not deploy in every type of collision.

Advanced Front Air Bags are designed to provide additional protection by supplementing the seat belts. Advanced Front Air Bags are not expected to reduce the risk of injury in rear, side, or rollover collisions.

The Advanced Front Air Bags will not deploy in all frontal collisions, including some that may produce substantial vehicle damage — for example, some pole collisions, truck underrides, and angle offset collisions.

On the other hand, depending on the type and location of impact, Advanced Front Air Bags may deploy in crashes with little vehicle front-end damage but that produce a severe initial deceleration.

Because air bag sensors measure vehicle deceleration over time, vehicle speed and damage by themselves are not good indicators of whether or not an air bag should have deployed.

Seat belts are necessary for your protection in all collisions, and also are needed to help keep you in position, away from an inflating air bag.

After any collision, the vehicle should be taken to an authorized dealer immediately.

Do not drive your vehicle after the air bags have deployed. If you are involved in another collision, the air bags will not be in place to protect you.

If it is necessary to modify the air bag system for persons with disabilities, contact your authorized dealer.

Refer to the Owner's Manual on the DVD for further details regarding the Supplemental Restraint System (SRS).

WARNING!

- Relying on the air bags alone could lead to more severe injuries in a collision. The air bags work with your seat belt to restrain you properly. In some collisions, the air bags won't deploy at all. Always wear your seat belts even though you have air bags.
- Being too close to the steering wheel or instrument panel during Advanced Front Air Bag deployment could cause serious injury, including death. Air bags need room to inflate. Sit back, comfortably extending your arms to reach the steering wheel or instrument panel.
- No objects should be placed over or near the air bag on the instrument panel or steering wheel because any such objects could cause harm if the vehicle is in a collision severe enough to cause the air bag to inflate.

Supplemental Side Air Bags

This vehicle is equipped with Supplemental Seat-Mounted Side Air Bags (SABs) located in the outboard side of the front seats. The SABs are marked with a SRS AIRBAG or AIRBAG label sewn into the outboard side of the seats.

This vehicle is equipped with Supplemental Side Air Bag Inflatable Curtains (SABICs) located above the side windows. The trim covering the SABICs is labeled SRS AIRBAG or AIRBAG. The SABICs may help reduce the risk of partial or complete ejection of vehicle occupants through side windows in certain side impact events.

The SABICs and SABs ("Side Air Bags") are designed to activate in certain side impacts. The Occupant Restraint Controller ("ORC") determines whether the deployment of the Side Air Bags in a particular impact event is appropriate, based on the severity and type of collision. Vehicle damage by itself is not a good indicator of whether or not Side Air Bags should have deployed.

WARNING!

- Side Air Bags need room to inflate. Do not lean against the door or window. Sit upright in the center of the seat.
- Being too close to the Side Air Bags during deployment could cause you to be severely injured or killed.
- Relying on the Side Air Bags alone could lead to more severe injuries in a collision. The Side Air Bags work with your seat belt to restrain you properly. In some collisions, Side Air Bags won't deploy at all. Always wear your seat belt even though you have Side Air Bags.
- This vehicle is equipped with left and right Supplemental Side Air Bag Inflatable Curtains (SABICs). Do not stack luggage or other cargo up high enough to block the deployment of the SABICs. The trim covering above the side windows where the SABIC and its deployment path are located should remain free from any obstructions.
- This vehicle is equipped with SABICs. In order for the SABICs to work as intended, do not install any accessory items in your vehicle which could alter the roof. Do not add an aftermarket sunroof to your vehicle. Do not add roof racks that require permanent attachments (bolts or screws) for installation on the vehicle roof. Do not drill into the roof of the vehicle for any reason.
- Do not use accessory seat covers or place objects between you and the Side Air Bags; the performance could be adversely affected and/or objects could be pushed into you, causing serious injury.

GETTING STARTED

Fuel Cut Off Switch

Your vehicle is equipped with a Fuel Cut Off safety switch. In the event of an accident, if the communication network remains intact, and the power remains intact, depending on the nature of the event, the Fuel Cut Off Switch may perform the following functions:

- Cut off fuel to the engine and turn off the engine.
- Flash hazard lights as long as the battery has power or until the hazard light button is pressed. The hazard lights can be deactivated by pressing the hazard light button.
- Turn on the interior lights, which remain on as long as the battery has power.
- Unlock the power door locks.

NOTE:

After an accident, remember to cycle the ignition to the STOP (OFF/LOCK) position and remove the key from the ignition switch to avoid draining the battery. Carefully check the vehicle for fuel leaks in the engine compartment and on the ground near the engine compartment and fuel tank before resetting the system and starting the engine. If there are no fuel leaks or damage to the vehicle electrical devices (e.g. headlights) after an accident, reset the Fuel Cut Off Switch by following the procedure described below.

Fuel Cut Off Switch Reset Procedure

- In order to reset the Fuel Cut Off Switch after an event push the “A” Button located underneath the front passenger seat knee impact bolster.

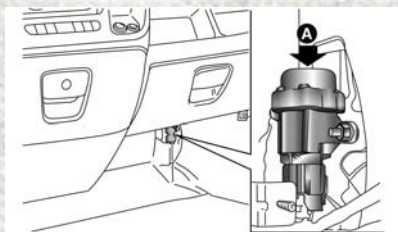

Fuel Cut Off Switch

WARNING!

If, after an accident, you smell fuel or see leaks from the fuel system, do not reset the Fuel Cut Off Switch to avoid the risk of fire.

Before reactivating the fuel cut off switch, carefully check for fuel leaks or damage to vehicle electrical devices (e.g. headlights).

Air Bag Warning Light

The air bags must be ready to inflate for your protection in a collision. The Occupant Restraint Controller (ORC) monitors the internal circuits and interconnecting wiring associated with air bag system electrical components.

The ORC monitors the readiness of the electronic parts of the air bag system whenever the ignition switch is in the AVV or MAR position. If the ignition switch is in the STOP position the air bag system is not on and the air bags will not inflate.

The ORC turns on the Air Bag Warning Light in the instrument panel for approximately four to eight seconds for a self-check when the ignition switch is first turned to the MAR position. After the self-check, the Air Bag Warning Light will turn off. If the ORC detects a malfunction in any part of the system, it turns on the Air Bag Warning Light, either momentarily or continuously. A single chime will sound to alert you if the light comes on again after initial startup.

If the Air Bag Warning Light in the instrument panel is not on during the four to eight seconds when the ignition switch is first turned to the MAR position, stays on, or turns on while driving, have the vehicle serviced by an authorized service center immediately.

NOTE:

If the speedometer, tachometer (if equipped), or any engine related gauges are not working, the Occupant Restraint Controller (ORC) may also be disabled. In this condition the air bags may not be ready to inflate for your protection. Have an authorized dealer service the air bag system immediately.

GETTING STARTED

Event Data Recorder (EDR)

This vehicle is equipped with an event data recorder (EDR). The main purpose of an EDR is to record, in certain crash or near crash-like situations, such as an air bag deployment or hitting a road obstacle, data that will assist in understanding how a vehicle's systems performed. The EDR is designed to record data related to vehicle dynamics and safety systems for a short period of time, typically 30 seconds or less. The EDR in this vehicle is designed to record such data as:

- How various systems in your vehicle were operating;
- Whether or not the driver and passenger safety belts were buckled/fastened;
- How far (if at all) the driver was depressing the accelerator and/or brake pedal; and,
- How fast the vehicle was traveling.

These data can help provide a better understanding of the circumstances in which crashes and injuries occur.

NOTE:

EDR data are recorded by your vehicle only if a non-trivial crash situation occurs; no data are recorded by the EDR under normal driving conditions and no personal data (e.g., name, gender, age, and crash location) are recorded. However, other parties, such as law enforcement, could combine the EDR data with the type of personally identifying data routinely acquired during a crash investigation.

To read data recorded by an EDR, special equipment is required, and access to the vehicle or the EDR is needed. In addition to the vehicle manufacturer, other parties, such as law enforcement, that have the special equipment, can read the information if they have access to the vehicle or the EDR.

CHILD RESTRAINTS

Children 12 years or younger should ride properly buckled up in a rear seat, if available. According to crash statistics, children are safer when properly restrained in the rear seats rather than in the front.

Every state in the United States and all Canadian provinces require that small children ride in proper restraint systems. This is the law, and you can be prosecuted for ignoring it.

NOTE:

- For additional information, refer to www.Seatcheck.org or call:

1-866-732-8243

- Canadian residents should refer to Transport Canada's website for additional information:
<http://www.tc.gc.ca/eng/motorvehiclesafety/safedrivers-childsafety-index-53.htm>

Installing Child Restraints In Commercial Vehicles

This commercial vehicle is not designed for use as a family vehicle and is not intended for carrying children in the front passenger seat(s). Never install rear-facing child restraints in this vehicle. Although the seat belt can be locked to secure a child restraint, there are no tether anchorages to complete the proper installation of a forward-facing child restraint. If you must carry a child in a forward-facing child restraint, the passenger seat should be moved to the full rearward position and the child must be in a proper restraint system based on its age, size and weight. Follow the instructions below to secure the child restraint using the seat belt.

WARNING!

Rear-facing infant restraints must never be secured in the passenger seat of a vehicle with a passenger Air Bag. In a collision, a passenger Air Bag may deploy causing severe injury or death to infants riding in rear-facing infant restraints.

Installing The Child Restraint Using The Vehicle Seat Belts

The seat belts in the passenger seating positions are equipped with a Switchable Automatic Locking Retractor (ALR) that is designed to keep the lap portion of the seat belt tight around the child restraint. Any seat belt system will loosen with time, so check the belt occasionally, and pull it tight if necessary.

To install a child seat using an ALR:

1. Pull enough of the seat belt webbing from the retractor to pass it through the belt path of the child restraint. Do not twist the belt webbing in the belt path.
2. Slide the latch plate into the buckle until you hear a “click.”
3. Pull on the webbing to make the lap portion tight against the child seat.
4. To lock the seat belt, pull down on the shoulder part of the belt until you have pulled all the seat belt webbing out of the retractor. Then, allow the webbing to retract back into the retractor. As the webbing retracts, you will hear a clicking sound. This means the seat belt is now in the Automatic Locking mode.
5. Try to pull the webbing out of the retractor. If it is locked, you should not be able to pull out any webbing. If the retractor is not locked, repeat the last step.
6. Finally, pull up on any extra webbing to tighten the lap portion around the child restraint while you push the child restraint rearward and downward into the vehicle seat.

GETTING STARTED

7. Test that the child restraint is installed tightly by pulling back and forth on the child seat at the belt path. It should not move more than 1 inch (25.4 mm) in any direction.

WARNING!

- In a collision, an unrestrained child, even a tiny baby, can become a projectile inside the vehicle. The force required to hold even an infant on your lap could become so great that you could not hold the child, no matter how strong you are. The child and others could be severely injured or killed. Any child riding in your vehicle should be in a proper restraint for the child's size.
- Rear-facing child seats must never be used in the front seat of a vehicle with a front passenger air bag. An air bag deployment could cause severe injury or death to infants in this position.
- Only use a rear-facing child restraint in a vehicle with a rear seat.

HEAD RESTRAINTS

Head restraints are designed to reduce the risk of injury by restricting head movement in the event of a rear impact. Head restraints should be adjusted so that the top of the head restraint is located above the top of your ear.

WARNING!

The head restraints for all occupants must be properly installed and adjusted prior to operating the vehicle or occupying a seat. Head restraints should never be adjusted while the vehicle is in motion. Driving a vehicle with the head restraints improperly adjusted or removed could cause serious injury or death in the event of a collision.

Front Head Restraints

To raise the head restraint, pull upward on the head restraint. To lower the head restraint, push the adjustment button located on the base of the head restraint and push downward on the head restraint.

To remove the head restraint, raise it up as far as it can go then push the adjustment button and the release button at the base of each post while pulling the head restraint up. To reinstall the head restraint, put the head restraint posts into the holes then adjust it to the appropriate height.

WARNING!

- A loose head restraint thrown forward in a collision or hard stop could cause serious injury or death to occupants of the vehicle. Always securely stow removed head restraints in a location outside the occupant compartment.
- ALL the head restraints MUST be reinstalled in the vehicle to properly protect the occupants. Follow the re-installation instructions above prior to operating the vehicle or occupying a seat.

NOTE:

Do not reposition the head restraint 180 degrees to the incorrect position in an attempt to gain additional clearance to the back of the head.

FRONT SEATS

Manual Front Seat Adjustments

The driver and passenger seats can be adjusted forward, rearward, reclined, front and rear height and lumbar adjustments.

WARNING!

- Adjusting a seat while driving may be dangerous. Moving a seat while driving could result in loss of control which could cause a collision and serious injury or death.
- Seats should be adjusted before fastening the seat belts and while the vehicle is parked. Serious injury or death could result from a poorly adjusted seat belt.

Forward And Rearward Adjustment

The adjusting bar is at the front of the seat, near the floor. Pull the bar upward to move the seat forward or rearward. Release the bar once the seat is in the desired position. Then, using body pressure, move forward and rearward on the seat to be sure that the seat adjusters have latched.

Lumbar Support — If Equipped

This feature allows you to increase or decrease the amount of lumbar support. The lumbar control knob is located on the rear upper outboard side of the driver's seatback. Rotate the control forward to increase and rearward to decrease the desired amount of lumbar support.

GETTING STARTED

Height Adjustment (Without Swivel Seat) — If Equipped

The height adjusting levers are located on the center outboard side of the seat. Lift up on the front lever to adjust the front of the seat up or down. Lift up on the rear lever to adjust the rear of the seat up or down.



Height Adjustment Levers

- 1 — Front Height Adjusting Lever
 - 2 — Rear Height Adjusting Lever
-

Height Adjustment (With Swivel Seat) — If Equipped

The height adjusting knobs are located on the center outboard side of the seat. Rotate the front knob to adjust the front of the seat up or down. Rotate the rear knob to adjust the rear of the seat up or down.



Height Adjustment Knobs

- 1 — Front Height Adjusting Knob
 - 2 — Rear Height Adjusting Knob
-

GETTING STARTED

Recliner Adjustment — Without Swivel Seat

The recliner knob is on the rear outboard side of the seat. To recline the seatback, lean back, rotate the knob rearward to position the seatback as desired. To return the seatback to its normal upright position, lean forward, rotate the knob forward until the seatback is in the upright position.



Recliner Knob

Recliner Adjustment — With Swivel Seat

The recliner lever is located at the lower front outboard side of the seat. To recline the seatback, lean forward slightly, pull the lever outward, lean back to the desired position and release the lever. To return the seatback to its normal upright position, lean forward and pull the lever outward. Release the lever once the seatback is in the upright position.



Recliner Lever

GETTING STARTED

WARNING!

- Adjusting a seat while the vehicle is moving is dangerous. The sudden movement of the seat could cause you to lose control. The seat belt might not be adjusted properly and you could be injured. Adjust the seat only while the vehicle is parked.
- Do not ride with the seatback reclined so that the shoulder belt is no longer resting against your chest. In a collision you could slide under the seat belt and be seriously or even fatally injured. Use the recliner only when the vehicle is parked.

Air Seat

The seat is equipped with a mechanical spring system and hydraulic shock absorber to ensure maximum comfort and safety. The system of springs also effectively absorbs impact from uneven road surfaces.

Damper Weight Adjustment

Use the weight adjustment knob to set the required setting based on body weight, with settings between 88 lbs (40 kg) and 286 lbs (130 kg).



Weight Adjustment Knob

Swivel Seat

The swivel seat lever is located at the lower front inboard side of the seat. The seat may be turned through 180° toward the seat on the opposite side and approximately 35° toward the door. The seat may be locked in the driving position or at the 180° position. To swivel the seat, pull the swivel seat inboard lever outward, turn the seat to the desired position and release the lever. The swivel seat back lever is located at the lower front outboard side of the seat, to tilt the seat back forward or rearward.

If the vehicle is equipped with interlocking swivel seats, the seats must be locked in facing forward position while driving. If the seats are not in the correct position, a warning will display in the EVIC.

If the driver or the passenger seats are not locked in facing forward position before the first vehicle movement, shifting out of park is not allowed until the seats are both locked in facing forward position. When the seats are not in the right position and the first vehicle movement after the cranking is attempted, a chime and a text message will appear in EVIC. Rotate and lock the swivel seats in the correct position before trying again.

If the driver or the passenger seats are not locked in facing forward position during movement of the vehicle, a message will be visualized in the EVIC and an intermittent chime will sound until key-off or until the swivel seats are locked in facing forward position. Stop and move the swivel seats in the correct position before proceeding.

If a fault is present in the system and it is not possible to check the correct position of the swivel seats, a message and the generic warning light appears in the EVIC to inform about the failure. In these conditions, check the status of the swivel seats and not drive the vehicle until the swivel seats are locked in facing forward position.



Swivel Seat Lever

GETTING STARTED

Adjustable Armrests

The seat adjustable armrest can be raised and adjusted for height. Underneath the front of the armrest is the adjuster wheel which will adjust the height of the armrest up or down.

Turn the adjuster wheel to the right or left to adjust the height of the armrest up or down.



Adjuster Wheel

HEATED SEATS

Heated Seats

On some models, the front driver and passenger seats may be equipped with heaters in both the seat cushions and seatbacks. The controls for the front heated seats are located on the lower outboard side of the seat.

Push the switch once to turn on the heated seats. Push the switch a second time to shut the heating elements off.

NOTE:

Once a heat setting is selected, heat will be felt within two to five minutes.



Heated Seat Switch

WARNING!

- Persons who are unable to feel pain to the skin because of advanced age, chronic illness, diabetes, spinal cord injury, medication, alcohol use, exhaustion or other physical condition must exercise care when using the seat heater. It may cause burns even at low temperatures, especially if used for long periods of time.
- Do not place anything on the seat or seatback that insulates against heat, such as a blanket or cushion. This may cause the seat heater to overheat. Sitting in a seat that has been overheated could cause serious burns due to the increased surface temperature of the seat.

TELESCOPING STEERING COLUMN

This feature allows you to lengthen or shorten the steering column. The telescoping control handle is located below the steering wheel at the end of the steering column.

To unlock the steering column, pull the control handle up. To lengthen or shorten the steering column, pull the steering wheel outward or push it inward as desired. To lock the steering column in position, push the control handle down until fully engaged.



Telescoping Control Handle

WARNING!

Do not adjust the steering column while driving. Adjusting the steering column while driving or driving with the steering column unlocked, could cause the driver to lose control of the vehicle. Failure to follow this warning may result in serious injury or death.

OPERATING YOUR VEHICLE

ENGINE BREAK-IN RECOMMENDATIONS

A long break-in period is not required for the engine and drivetrain (transmission and axle) in your vehicle.

Drive moderately during the first 300 miles (500 km). After the initial 60 miles (100 km), speeds up to 50 or 55 mph (80 or 90 km/h) are desirable.

While cruising, brief full-throttle acceleration within the limits of local traffic laws contributes to a good break-in. Wide-open throttle acceleration in low gear can be detrimental and should be avoided.

The engine oil installed in the engine at the factory is a high-quality energy conserving type lubricant. Oil changes should be consistent with anticipated climate conditions under which vehicle operations will occur. Refer to “Maintaining Your Vehicle,” for the recommended viscosity and quality grades.

NOTE:

A new engine may consume some oil during its first few thousand miles (kilometers) of operation. This should be considered a normal part of the break-in and not interpreted as an indication of an engine problem or malfunction.

CAUTION!

Never use Non-Detergent Oil or Straight Mineral Oil in the engine or damage may result.

OPERATING YOUR VEHICLE

MANUAL CLIMATE CONTROLS



Manual Climate Controls

- 1 — Rotate Blower Control
- 2 — Push Air Recirculation Button
- 3 — Rotate Temperature Control
- 4 — Push A/C Button

- 5 — Rotate Mode Control
- 6 — Push Rear Window Defroster Button

Air Recirculation

- Use Recirculation for maximum A/C operation.
- For window defogging, turn the Recirculation button off.
- Recirculation is not allowed in defrost.
- Recirculation is allowed in floor mode and defrost/floor (mix modes) for approximately five minutes.

Heated Mirrors — If Equipped

The mirrors are heated to melt frost or ice. This feature is activated whenever you turn on the rear window defroster.

OPERATING YOUR VEHICLE

MULTIFUNCTION LEVER

The multifunction lever controls the operation of the headlights, parking lights, turn signals, headlight beam selection and the passing lights. The multifunction lever is located on the left side of the steering column.



Turn Signal Headlight Lever

- 1 — High Beams
- 2 — Headlights
- 3 — Turn Signals

Turn Signals

Move the multifunction lever up or down and the arrows on each side of the instrument cluster flash to show proper operation of the front and rear turn signal lights.

NOTE:

If either light remains on and does not flash, or there is a very fast flash rate, check for a defective outside light bulb. If an indicator fails to light when the lever is moved, it would suggest that the indicator bulb is defective.

Headlights

To turn on the headlights, turn the end of the multifunction lever to the headlight position. When the headlight switch is on, the parking lights, taillights, license plate light, the clearance lights and instrument panel lights are also turned on. To turn off the headlights, turn the end of the multifunction lever back to the O (Off) position.

High Beam/Low Beam Select Switch

Pull the multifunction lever toward you to switch the headlights to high beam. Pull the lever a second time to switch the headlights back to low beam.

Lane Change Assist

Tap the lever up or down once, without moving beyond the detent, and the turn signal (right or left) will flash five times then automatically turn off.

Parking Lights

These lights can only be turned on with ignition key in the STOP position or removed, by moving the end of the multifunction lever to O (off) position and then to the headlight position.

The warning light telltale in the instrument panel comes on. The lights stay on until the next ignition cycle is performed.

INTERIOR LIGHTS

Interior Lights

These lights are mounted between the sun visors on the overhead shelf. Each light is turned on by pushing the corresponding switch.

Dome Lights

The interior lights can be set to three different positions (Off/Left Position, Center Position, On/Right Position). Using the switch on the bottom of the overhead console:

- Push the switch to the on/right position from its center position and the lights are always on.
- Push the switch to the off/left position from its center position and the lights are always off.
- Leave the switch in the center position, and the lights are turned on and off when the doors are opened or closed.

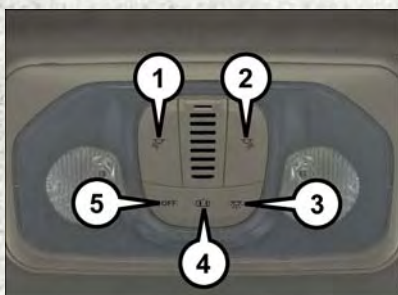

Overhead Lights

- 1 — Left Map Light
- 2 — Right Map Light
- 3 — On/Right Position
- 4 — Center Position
- 5 — Off/Left Position

Map Lights

The switches on the left and right sides of the overhead console controls the map or reading function of the lights. Push the switch on the right to turn the right light on and push the switch on the left to turn the left light on.

CAUTION!

Before getting out of the vehicle be sure that the switch is in the center position or that the lights are off to avoid draining the battery.

OPERATING YOUR VEHICLE

Dimmer Controls

The dimmer controls are located on the left side of the instrument panel below the instrument cluster.

Pushing the up or down arrow will increase or decrease the brightness of the instrument panel lights.

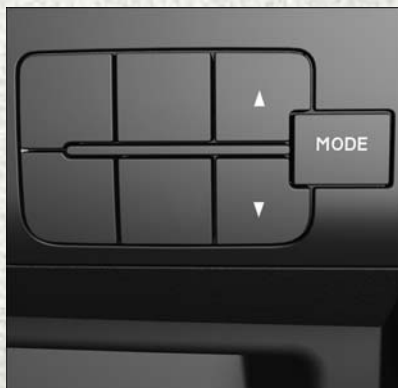

Dimmer Controls

Cargo Lamp

The Rear Cargo Lamp is located at the upper rear cargo area above the rear doors.

Your vehicle may be equipped with a Side Cargo Lamp located at the upper rear area of the passenger side sliding door opening.

The Cargo Lamps can be set to three different positions (Off/Right Position, Center Position, On/Left Position).

- Push the Cargo Lamp lens to the right from its center position and the lamp is always off.
- Leave the Cargo Lamp lens in the center position, and the lamp is turned on and off when the sliding doors or rear doors are opened or closed.
- Push the Cargo Lamp lens to the left from its center position and the lamp is always on.

OPERATING YOUR VEHICLE

WINDSHIELD WIPERS AND WASHERS

Windshield Wipers

The windshield wiper/washer lever is located on the right side of the steering column. There are five different modes of operation for the front windshield wipers. The windshield wiper lever can be raised or lowered to access the modes.

NOTE:

The windshield wipers/washers will only operate with the ignition in the ON/RUN position.



Wiper Washer Lever

- 1 — Mist
 - 2 — Intermittent, Low And High
 - 3 — Washer
-

Intermittent Wiper System

Push the lever downward to the first detent and rotate the center ring to use one of the four intermittent wiper settings when weather conditions make a single wiping cycle, with a variable delay between cycles, desirable.

Low Speed

Push the lever downward to the second detent. The wipers will operate at low speed.

High Speed

Push the lever downward to the third detent. The wipers will operate at high speed.

OPERATING YOUR VEHICLE

Mist Feature

Use the Mist feature when weather conditions make occasional usage of the wipers necessary. Push the lever upward to the Mist position and release for a single wiping cycle.

NOTE:

The mist feature does not activate the washer pump; therefore, no washer fluid will be sprayed on the windshield. The wash function must be used in order to spray the windshield with washer fluid.

Windshield Washer Operation

To use the washer, pull the windshield wiper/washer lever toward the steering wheel to activate the washers. The wipers will activate automatically for three cycles after the lever is released, and then resume the intermittent interval previously selected.

If the lever is pulled while in the off position, the wipers will operate for three cycles, then turn off.

WARNING!

Sudden loss of visibility through the windshield could lead to a collision. You might not see other vehicles or other obstacles. To avoid sudden icing of the windshield during freezing weather, warm the windshield with the defroster before and during windshield washer use.

OPERATING YOUR VEHICLE

ELECTRONIC SPEED CONTROL

When engaged, the Electronic Speed Control takes over accelerator operations at speeds greater than 25 mph (40 km/h) up to the maximum speed of 100 mph (160 km/h).

The Electronic Speed Control Lever is located on the left side of the steering column.



Electronic Speed Control Lever

- 1 — Set/Accel
- 2 — On/Off
- 3 — Resume
- 4 — Decel

NOTE:

In order to ensure proper operation, the Electronic Speed Control System has been designed to shut down if multiple Speed Control functions are operated at the same time. If this occurs, the Electronic Speed Control System can be reactivated by rotating the Electronic Speed Control ON/OFF center ring and resetting the desired vehicle set speed.

OPERATING YOUR VEHICLE

To Activate

Rotate the center ring upward on the electronic speed control lever to turn the system ON. The Cruise Indicator Light in the instrument cluster will illuminate. To turn the system OFF, rotate the center ring upward a second time. The Cruise Indicator Light will turn off. The system should be turned off when not in use.

WARNING!

Leaving the Electronic Speed Control system on when not in use is dangerous. You could accidentally set the system or cause it to go faster than you want. You could lose control and have an accident. Always leave the system OFF when you are not using it.

To Set A Desired Speed

Turn the Electronic Speed Control ON. When the vehicle has reached the desired speed, move the electronic speed control lever upward SET(+) and release. Release the accelerator and the vehicle will operate at the selected speed.

NOTE:

The vehicle should be traveling at a steady speed and on level ground before moving the electronic speed control lever upward SET(+).

To Deactivate

A soft tap on the brake pedal, pushing the RES button, or normal brake pressure while slowing the vehicle will deactivate Electronic Speed Control without erasing the set speed memory. Rotating the center ring upward to turn the system OFF or turning the ignition switch OFF erases the set speed memory.

To Resume Speed

To resume a previously set speed, push the RES button and release. Resume can be used at any speed above 20 mph (32 km/h) up to the maximum speed of 100 mph (160 km/h).

Accel/Decel

To Increase Speed

When the Electronic Speed Control is set, you can increase speed by tapping the Speed Control lever up (+).

The drivers preferred units can be selected through the radio settings if equipped. Refer to "Uconnect Settings" in "Understanding Your Instrument Panel" on the DVD for more information. The speed increment shown is dependant on the chosen speed unit of U.S. (mph) or Metric (km/h):

U.S. Speed (mph)

- Tapping the Speed Control lever up (+) once will result in a 1 mph increase in set speed. Each subsequent tap of the lever results in an increase of 1 mph.
- If the lever is continually held up, the set speed will continue to increase until the lever is released, then the new set speed will be established.

Metric Speed (km/h)

- Tapping the Speed Control lever up (+) once will result in a 1 km/h increase in set speed. Each subsequent tap of the lever results in an increase of 1 km/h.
- If the lever is continually held up, the set speed will continue to increase until the lever is released, then the new set speed will be established.

To Decrease Speed

When the Electronic Speed Control is set, you can decrease speed by tapping the Speed Control lever down (-).

The drivers preferred units can be selected through the radio settings if equipped. Refer to "Uconnect Settings" in "Understanding Your Instrument Panel" on the DVD for more information. The speed increment shown is dependant on the chosen speed unit of U.S. (mph) or Metric (km/h):

U.S. Speed (mph)

- Tapping the Speed Control lever down (-) once will result in a 1 mph decrease in set speed. Each subsequent tap of the lever results in a decrease of 1 mph.
- If the lever is continually held down, the set speed will continue to decrease until the lever is released, then the new set speed will be established.

OPERATING YOUR VEHICLE

Metric Speed (km/h)

- Tapping the Speed Control lever down (-) once will result in a 1 km/h decrease in set speed. Each subsequent tap of the lever results in a decrease of 1 km/h.
- If the lever is continually held down, the set speed will continue to decrease until the lever is released, then the new set speed will be established.

To Accelerate For Passing

Press the accelerator as you would normally. When the pedal is released, the vehicle will return to the set speed.

Using Electronic Speed Control On Hills

The transmission may downshift on hills to maintain the vehicle set speed.

NOTE:

The Electronic Speed Control system maintains speed up and down hills. A slight speed change on moderate hills is normal.

On steep hills, a greater speed loss or gain may occur so it may be preferable to drive without Electronic Speed Control.

WARNING!

Electronic Speed Control can be dangerous where the system cannot maintain a constant speed. Your vehicle could go too fast for the conditions, and you could lose control and have an accident. Do not use Electronic Speed Control in heavy traffic or on roads that are winding, icy, snow-covered or slippery.

PARKSENSE REAR PARK ASSIST

If an object is detected behind the rear bumper while the vehicle is in REVERSE, a chime sounds. The chime rate changes depending on the distance of the object, getting faster as the object gets closer to the bumper. The chime sounds off continuously when the distance between the vehicle and the obstacle is less than 12 inches (30 cm).

OPERATING YOUR VEHICLE

PARKVIEW REAR BACK-UP CAMERA

You can see an on-screen image of the rear of your vehicle whenever the gear selector is put into REVERSE. The ParkView Rear Back-Up Camera image is displayed on the touchscreen display located on the center stack of the instrument panel.

NOTE:

If the touchscreen display appears foggy, clean the camera lens located on the top rear of the vehicle below the center light.

WARNING!

Drivers must be careful when backing up even when using the Rear Back Up Camera. Always check carefully behind your vehicle, and be sure to check for pedestrians, animals, other vehicles, obstructions, or blind spots before backing up. You are responsible for the safety of your surroundings and must continue to pay attention while backing up. Failure to do so can result in serious injury or death.



YOUR VEHICLE'S SOUND SYSTEM

1. Steering Wheel Audio Controls (Left) pg. 63
2. Uconnect Phone Mute Button
3. Uconnect Phone Button pg. 54
4. Steering Wheel Audio Controls (Right) pg. 63
5. Phone Hang Up Button
6. Uconnect Voice Command Button pg. 47
7. USB/Audio Jack pg. 46
8. Volume Knob pg. 42



- 9. Eject Button pg. 42
- 10. CD Slot pg. 45
- 11. Uconnect Radio pg. 42
- 12. SETTINGS Button
- 13. Tune/Scroll Knob/Browse/Enter Button
- 14. Front Power Outlet/Cigar Lighter pg. 64
- 15. USB Port (Charging Only)

CYBERSECURITY

Your vehicle may be a connected vehicle and may be equipped with both wired and wireless networks. These networks allow your vehicle to send and receive information. This information allows systems and features in your vehicle to function properly.

Your vehicle may be equipped with certain security features to reduce the risk of unauthorized and unlawful access to vehicle systems and wireless communications. Vehicle software technology continues to evolve over time and FCA US LLC, working with its suppliers, evaluates and takes appropriate steps as needed. Similar to a computer or other devices, your vehicle may require software updates to improve the usability and performance of your systems or to reduce the potential risk of unauthorized and unlawful access to your vehicle systems.

The risk of unauthorized and unlawful access to your vehicle systems may still exist, even if the most recent version of vehicle software (such as Uconnect software) is installed.

WARNING!

- It is not possible to know or to predict all of the possible outcomes if your vehicle's systems are breached. It may be possible that vehicle systems, including safety related systems, could be impaired or a loss of vehicle control could occur that may result in an accident involving serious injury or death.
- ONLY insert media (e.g., USB, SD card, or CD) into your vehicle if it came from a trusted source. Media of unknown origin could possibly contain malicious software, and if installed in your vehicle, it may increase the possibility for vehicle systems to be breached.
- As always, if you experience unusual vehicle behavior, take your vehicle to your nearest authorized dealer immediately.

NOTE:

- FCA or your dealer may contact you directly regarding software updates.
- To help further improve vehicle security and minimize the potential risk of a security breach, vehicle owners should:
 - Routinely check www.driveuconnect.com/software-update to learn about available Uconnect software updates.
 - Only connect and use trusted media devices (e.g. personal mobile phones, USBs, CDs).

Privacy of any wireless and wired communications cannot be assured. Third parties may unlawfully intercept information and private communications without your consent. For further information, refer to "Onboard Diagnostic System (OBD II) Cybersecurity" in "Maintaining Your Vehicle" in your Owner's Manual on the DVD.

IDENTIFYING YOUR RADIO

Uconnect RH3

- Single Din Mono-Chromatic Display



Uconnect RH3

Uconnect 5.0

- 5.0" Full Color Touchscreen Display
- Single Disc CD Player
- Bluetooth Connectivity/Bluetooth Streaming Audio



Uconnect 5.0

UCONNECT RH3



Uconnect RH3

- 1 — On/Off Volume Knob
- 2 — Display
- 3 — SEEK Down Button
- 4 — Mute/Pause Button
- 5 — SEEK Up Button
- 6 — Source Button
- 7 — Menu Button

- 8 — RND Button
- 9 — Display Button
- 10 — Band/As Button
- 11 — Preset Buttons
- 12 — Audio Button
- 13 — Fast Track Button

Enable Or Disable Clock

1. Push the DISP button for more than two seconds to enable or disable the Clock.
2. When this function is enabled, the display shows the message "CLK ON" and the clock is displayed whenever the ignition is On, even with the radio Off. In 10 seconds if no radio key is pushed, the display returns to the clock.
3. When this function is disabled, the message "CLK OFF" is displayed on the radio display.

NOTE:

This procedure sets the time on the radio clock ONLY. To set the time in the Electronic Vehicle Information Center, please refer to the section titled Electronic Vehicle Information Center (EVIC) in this manual.

Equalizer, Balance And Fade

- Adjust Equalizer of bass and treble
- Balance left/right (BALANCE) and front/rear (FADER)
- Strengthen sound (loudness)

Equalization

- Push the AUDIO button for more than two seconds to access equalization: ROCK, CLASSIC, POP, VOCAL, JAZZ, USER or FLAT.
- Pushing AUDIO more than once changes equalization options. If this button is not pushed again for five seconds or the ROTARY is pushed, the display returns to the previously selected view and the adjustments made is saved.

Balance, Fade, Loudness, Bass And Treble

- Pushing the AUDIO button for less than two seconds accesses an audio function.
- Pushing AUDIO more than once accesses other functions (e.g. Bass, Treble, Balance, Fader, Loudness and Bass). If this key is not pushed again for five seconds or the ROTARY is pushed, the display returns to the previously selected view and the adjustments made is saved. The Bass and Treble functions are only accessible if the USER EQ has been selected.

Radio Operation

Seek Up/Seek Down

- Push the “double arrows” to the left for less than two seconds to seek down to the next station. Push the “double arrows” to the right for less than two seconds to seek up to the next station.
- Hold either button to bypass stations without stopping.

Store Radio Presets Manually

1. Tune to the desired station.
2. Push and hold the desired numbered memory button (1 through 6) for more than three seconds.

USB/MP3 Audio Jack

USB/iPod Mode is entered by inserting a USB Jump Drive or an iPod cable into the USB port.

CAUTION!

To remove devices connected to the USB port, first select the other audio source. Failure to follow this procedure can cause damage to the connected device. Due to the extensive range of makes and models of storage devices available on the market, not all devices have compatibility required for proper functioning of Vehicle Radios. Use only quality USB devices.

ELECTRONICS

Forward/Reverse Folder

- Push the button memory one (1) to advance to the first track of the next folder that contains audio files. Push the button memory two (2) to go back to the first track in the previous folder that contains audio files. When this operation is performed, the display shows the name of the selected folder.

Song Shuffle

- Push the RND to "shuffle songs." When enabled, "RND ON" is on the displayed for two seconds. After this period the display reverts to the previous view. When this button is pushed again, the function is disabled, and the display indicates "RND OFF" for two seconds. After this period the display reverts to the view previously selected.

UCONNECT 5.0



Uconnect 5.0

- | | |
|--------------------------------|-------------------------------|
| 1 — Disc Eject Button | 8 — COMPASS/NAV — If Equipped |
| 2 — Disc Slot | 9 — MEDIA Button |
| 3 — Settings Button | 10 — RADIO Button |
| 4 — Back Button | 11 — On/Off — Volume Knob |
| 5 — Browse/Enter — Tune/Scroll | 12 — Mute Button |
| 6 — MORE Button | 13 — SCREEN ON/OFF |
| 7 — Uconnect PHONE | |

Clock Setting

1. To start the clock setting procedure, push the SETTINGS  button on the right side of the display, then “Clock & Date” button on the touchscreen, and then “Set Time & Format” button on the touchscreen. Select the up or down arrows as appropriate.
2. Press the “Up or Down arrows” to adjust the hours or minutes, next select the AM or PM button on the touchscreen. You can also select 12hr or 24hr format by pressing the desired button on the touchscreen.
3. Once the time is set press the “Done” or “back arrow” button on the touchscreen to exit the time screen.

NOTE:

Once the time has been set on the radio, the time will also appear in the Electronic Vehicle Information Center (EVIC).

Equalizer, Balance And Fade

1. Push the SETTINGS  button on the right side of the display.
2. Scroll down and press the “Audio” button on the touchscreen to open the Audio menu.
3. The Audio Menu shows the following options for you to customize your audio settings.

Equalizer

- Press the “Equalizer” button on the touchscreen to adjust the Bass, Mid and Treble. Use the “+” or “-” buttons on the touchscreen to adjust the equalizer to your desired settings.

Balance/Fade

- Press the “Balance/Fade” button on the touchscreen to adjust the sound from the speakers. Use the “arrow” buttons on the touchscreen to adjust the sound level from the front and rear or right and left side speakers. Press the Center “C” button on the touchscreen to reset the balance and fade to the factory setting.

Speed Adjusted Volume

- Press the “Speed Adjusted Volume” button on the touchscreen to select between OFF, 1, 2 or 3. This decreases the radio volume relative to a decrease in vehicle speed.

Loudness

- Press the “Loudness” button on the touchscreen to select the Loudness feature. When this feature is activated it improves sound quality at lower volumes.

Auto-On Radio

- Press the “Auto-On Radio” button on the touchscreen, select On, Off, or Recall Last followed by pressing “Done” or the “back arrow” button on the touchscreen. When this feature is activated, the radio automatically turns on when the vehicle is in run or recalls whether it was on or off at last ignition off.

Radio Operation

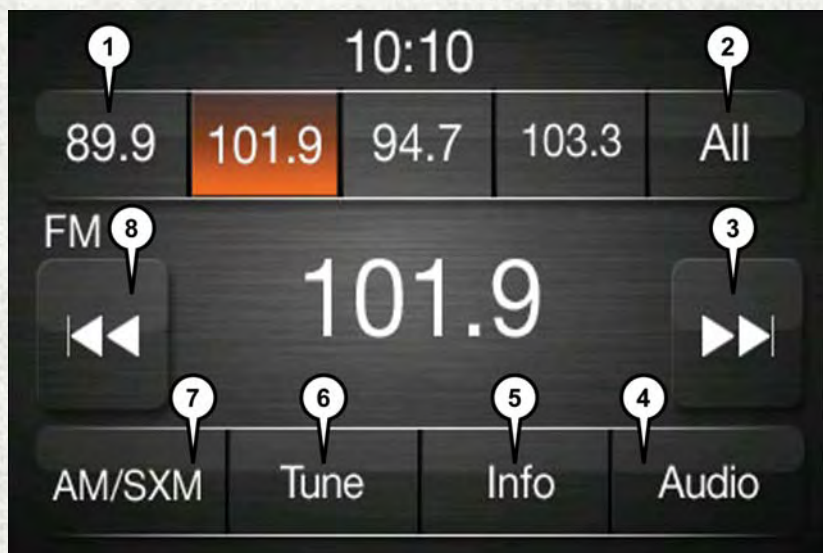

Uconnect 5.0/5.0N Radio

- 1 — Radio Station Presets
- 2 — Show All Presets
- 3 — Seek Up
- 4 — Audio Settings

- 5 — Station Info
- 6 — Direct Tune
- 7 — Radio Band
- 8 — Seek Down

Seek Up/Down Buttons

- Push the up or down button to seek through radio stations in AM, FM or SXM bands.
- Hold either button to bypass stations without stopping.

Store Radio Presets Manually

The Radio stores up to 12 presets in each of the Radio modes. There are four visible presets at the top of the radio screen. Pressing the “All” button on the touchscreen will display all of the preset stations for that mode.

To store a radio preset manually, follow the steps below:

1. Tune to the desired station.
2. Press and hold the desired numbered button on the touchscreen for more than two seconds, or until you hear a confirmation beep.

SiriusXM Premier Over 160 Channels

Get every channel available on your satellite radio, and enjoy all you want, all in one place. Hear commercial-free music plus sports, news, talk and entertainment. Get all the premium programming, including Howard Stern, every NFL game, Oprah Radio, every MLB and NHL game, every NASCAR race and more. And get 20+ Xtra channels, including SiriusXM Latino, a selection of channels dedicated to Spanish language programming.

- To access SiriusXM Satellite Radio, push the RADIO button on the faceplate and then the “SXM” button on the touchscreen.

SiriusXM services require subscriptions, sold separately after the 12-month trial included with the new vehicle purchase. **If you decide to continue your service at the end of your trial subscription, the plan you choose will automatically renew and bill at then-current rates until you call SiriusXM at 1-866-635-2349 for U.S. residents and 1-888-539-7474 for Canadian residents to cancel. U.S. residents see SiriusXM Customer Agreement for complete terms at www.siriusxm.com. Canadian residents should visit www.siriusxm.ca for complete terms.** All fees and programming subject to change. Our satellite service is available only to those at least 18 and older in the 48 contiguous USA and D.C. Our Sirius satellite service is also available in PR (with coverage limitations). Our Internet radio service is available throughout our satellite service area and in AK. © 2015 Sirius XM Radio Inc. Sirius, XM and all related marks and logos are trademarks of Sirius XM Radio Inc.

Disc Operation

- CD/Disc Mode is entered by either inserting a CD/Disc or by pushing the MEDIA button located below the display. Once in Media Mode, select Disc.
- Gently insert one CD into the CD player with the CD label facing up.

Seek Up/Down Buttons

- Press to seek through Disc tracks.
- Hold either button to bypass tracks without stopping.

Browse

- Press the “browse” button on the touchscreen to scroll through and select a desired track on the Disc. Press the “exit” button on the touchscreen if you wish to cancel the browse function.

USB/Audio Jack (AUX)/Bluetooth Operation

USB/iPod

The USB Input and Auxiliary Jack is located on the instrument panel left of the radio (driver's lower right).

- USB/iPod Mode is entered by either inserting a USB Jump Drive or an iPod cable into the USB port or by pushing the MEDIA button on the faceplate located below the display. Once in Media Mode, press the "Source" button on the touchscreen and select USB/iPod
- Push the MEDIA button on the faceplate, press the "Source" button on the touchscreen then select USB/iPod to change the mode to the USB device. If the device is connected, music from your portable device plays through the vehicle's speakers.



USB/Audio Jack

- 1 — USB Port
- 2 — AUX/Audio Jack

Audio Jack (AUX)

The AUX jack allows a portable device, such as an MP3 player or an iPod, to be plugged into the radio and utilize the vehicle's audio system. Using a 3.5 mm audio jack plugged into the AUX jack will amplify the source and play the music through the vehicle speakers.

- Push the MEDIA button on the faceplate, press the "Source" button on the touchscreen then select AUX to change the mode to the AUX device. If the device is connected in play mode, music from your portable device will play through the vehicle's speakers.
- The functions of the portable device are controlled using the device. However, the volume may be controlled using the radio or portable device.

Bluetooth

If using a Bluetooth - equipped device, you may also be able to stream music through your vehicle's sound system.

- Push the MEDIA button on the faceplate, press the "Source" button on the touchscreen then select Bluetooth to change the mode to Bluetooth. If the device is paired, music from your portable device plays through the vehicle's speakers.

Uconnect 5.0 Available Media Hubs

Uconnect 5.0	Media Hub (USB, AUX Ports)
	S

S = Standard Equipment

Navigation

If your vehicle is equipped with Navigation, there will be a NAV button on the faceplate in place of the COMPASS button on the faceplate. See your Uconnect Supplement manual or www.ramtrucks.com/promaster for additional information.

UCONNECT 5.0 VOICE RECOGNITION QUICK TIPS

Introducing Uconnect

Start using Uconnect Voice Recognition with these helpful quick tips. It provides the key Voice Commands and tips you need to know to control your Uconnect 5.0 system.

Key Features:

- Five-inch Color Touchscreen Display with AM/FM/USB/Bluetooth
- Bluetooth with integrated voice control
- GPS navigation (if equipped)



Uconnect 5.0

Get Started

1. Visit **UconnectPhone.com** to check mobile device and feature compatibility and to find phone pairing instructions.
2. Reduce background noise. Wind and passenger conversations are examples of noise that may impact recognition.
3. Speak clearly at a normal pace and volume while facing straight ahead. The microphone is positioned on the rearview mirror and aimed at the driver.
4. Each time you give a Voice Command, you must first push either the VR or Phone button, wait until **after** the beep, then say your Voice Command.
5. You can interrupt the help message or system prompts by pushing the VR or Phone button and saying a Voice Command from current category.

All you need to control your Uconnect system with your voice are the buttons on your steering wheel.



Uconnect VR/Phone Buttons

- 1 — Push To Mute
- 2 — Push To Initiate Or To Answer A Phone Call, Send Or Receive A Text
- 3 — Push To End Call
- 4 — Push To Begin Radio Or Media Functions

Basic Voice Commands

The basic Voice Commands below can be given at any point while using your Uconnect system.

Push the VR button . After the beep, say:

- **Cancel** to stop a current voice session
- **Help** to hear a list of suggested Voice Commands
- **Repeat** to listen to the system prompts again

Notice the visual cues that inform you of your voice recognition system's status. Cues appear on the touchscreen.

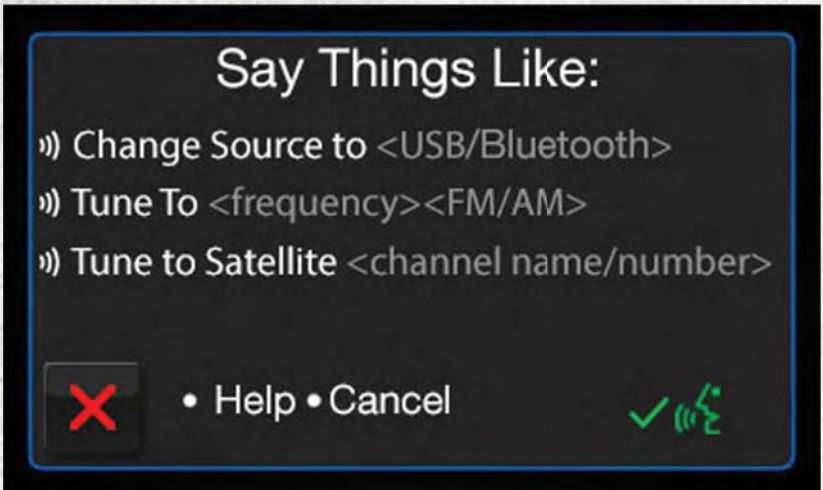

Uconnect 5.0/5.0N Visual Cues

Radio

Use your voice to quickly get to the AM, FM or SiriusXM Satellite Radio stations you would like to hear. (Subscription or included SiriusXM Satellite Radio trial required.)

Push the VR button . After the beep, say:

- **Tune to** ninety-five-point-five FM
- **Tune to** Satellite Channel Hits 1

TIP: At any time, if you are not sure of what to say or want to learn a Voice Command, push the VR button  and say **“Help.”** The system will provide you with a list of commands.



Uconnect 5.0 Radio

Media

Uconnect offers connections via USB, SD, Bluetooth and auxiliary ports (If Equipped). Voice operation is only available for connected USB and iPod devices. (Remote CD player optional and not available on all vehicles.)

Push the VR button . After the beep, say one of the following commands and follow the prompts to switch your media source or choose an artist.

- **Change source to** Bluetooth
- **Change source to** iPod
- **Change source to** USB
- **Play artist** Beethoven; **Play album** Greatest Hits; **Play song** Moonlight Sonata; **Play genre** Classical

TIP: Press the Browse button on the touchscreen to see all of the music on your iPod or USB device. Your Voice Command must match **exactly** how the artist, album, song and genre information is displayed.

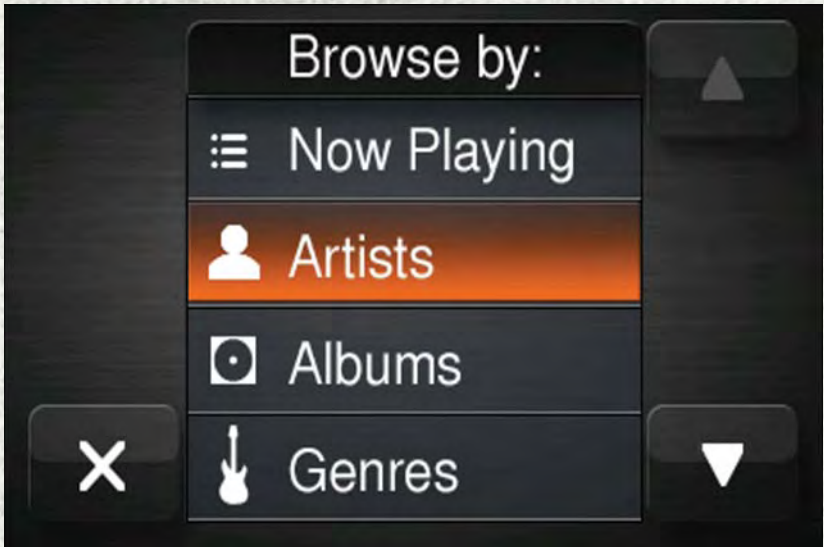

Uconnect 5.0 Media

Phone

Making and answering hands-free phone calls is easy with Uconnect. When the Phonebook button is illuminated on your touchscreen, your system is ready.

U.S. residents can visit UconnectPhone.com to check mobile device and feature compatibility and to find phone pairing instructions.

Push the Phone button . After the beep, say one of the following commands...

- **Call** John Smith
- **Dial** 123-456-7890 and follow the system prompts
- **Redial** (call previous outgoing phone number)
- **Call back** (call previous incoming phone number)

TIP: When providing a Voice Command, push the Phone button  and say “**Call,**” then pronounce the name **exactly** as it appears in your phone book. When a contact has multiple phone numbers, you can say “**Call** John Smith **work.**”



Uconnect 5.0 Phone

Voice Text Reply

Uconnect will announce **incoming** text messages. Push the Phone button  and say **Listen**. (Must have compatible mobile phone paired to Uconnect system.)

1. Once an incoming text message is read to you, push the Phone button . After the beep, say: **Reply**
2. Listen to the Uconnect prompts. After the beep, repeat one of the pre-defined messages and follow the system prompts.

TIP: Your mobile phone must have the full implementation of the **Message Access Profile (MAP)** to take advantage of this feature. For details about MAP, visit UconnectPhone.com for U.S. residents. Apple iPhone iOS6 or later supports reading **incoming** text messages only.

PRE-DEFINED VOICE TEXT REPLY RESPONSES

Yes.	Stuck in Traffic.	See you later.
No.	Start without me.	I'll be Late.
Okay.	Where are you?	I will be <number> minutes late.
Call me.	Are you there yet?	
I'll call you later.	I need directions.	See you in <number> of minutes.
I'm on my way.	Can't talk right now.	
I'm lost.		Thanks.

Additional Information

© 2015 FCA US LLC. All rights reserved. Mopar, Mopar Owner Connect and Uconnect are registered trademarks of FCA US LLC. Android is a trademark of Google Inc. SiriusXM and all related marks and logos are trademarks of SiriusXM Radio Inc. Yelp, Yelp logo, Yelp burst and related marks are registered trademarks of Yelp.

Uconnect System Support:

- U.S. residents visit DriveUconnect.com or call: 1-877-855-8400 (24 hours a day 7 days a week)
- Canadian residents visit DriveUconnect.ca or call: 1-800-465-2001 (English) or 1-800-387-9983 (French)

Mon. – Fri., 8:00 am – 8:00 pm, ET

Sat., 9:00 am – 5:00 pm, ET

Sun., Closed

Uconnect Access Services Support 1-855-792-4241. Please have your Uconnect Security PIN ready when you call.

UCONNECT PHONE

Uconnect Phone (Bluetooth Hands Free Calling)



Uconnect 5.0/5.0N Phone Menu

- | | |
|--------------------------------------|--|
| 1 — Call/Redial/Hold | 7 — Uconnect Phone Settings Menu |
| 2 — Mobile Phone Signal Strength | 8 — Text Messaging |
| 3 — Currently Paired Mobile Phone | 9 — Direct Dial Pad |
| 4 — Mobile Phone Battery Life | 10 — Recent Call Log |
| 5 — Mute Microphone | 11 — Browse Phone Book
(Contains 911) |
| 6 — Transfer To/From Uconnect System | 12 — End Call |

The Uconnect Phone feature enables you to place and receive hands-free mobile phone calls. Drivers can also place mobile phone calls using their voice or by using the buttons on the touchscreen (see Voice Command section).

The hands-free calling feature is made possible through Bluetooth technology — the global standard that enables different electronic devices to connect to each other wirelessly.

If the Uconnect Phone Button  exists on your steering wheel, you then have the Uconnect Phone features.

Refer to the “Understand The Features Of Your Vehicle” section of your vehicle's Owner's Manual on the DVD for further details.

NOTE:

- The Uconnect Phone requires a mobile phone equipped with the Bluetooth Hands-Free Profile, Version 1.0 or higher.
- Most mobile phones/devices are compatible with the Uconnect system, however some mobile phones/devices may not be equipped with all of the required features to utilize all of the Uconnect system features.
- For Uconnect Customer Care:
 - U.S. residents visit UconnectPhone.com or call 1-877-855-8400.
 - Canadian Residents visit UconnectPhone.com or call, 1-800-465-2001 (English) or 1-800-387-9983 (French).

Pairing (Wirelessly Connecting) Your Mobile Phone To The Uconnect System

Mobile phone pairing is the process of establishing a wireless connection between a cellular phone and the Uconnect system.

NOTE:

- To use the Uconnect Phone feature, you first must determine if your mobile phone and software are compatible with the Uconnect system. Please visit UconnectPhone.com for complete mobile phone compatibility information.
- Mobile phone pairing is not available while the vehicle is in motion.
- A maximum of 10 mobile phones can be paired to the Uconnect system.

Start Pairing Procedure On The Radio

Uconnect 5.0/5.0N:

1. Place the ignition in the ACC or ON position.
2. Press the “Phone” button.
3. Select “Settings.”
4. Select “Paired Phones.”
5. Select “Add device.”

NOTE:

Uconnect Phone will display an “In progress” screen while the system is connecting.



Uconnect 5.0/5.0N

Pair Your iPhone:

To search for available devices on your Bluetooth enabled iPhone:

1. Press the Settings button.
2. Select Bluetooth.
 - Ensure the Bluetooth feature is enabled. Once enabled, the mobile phone will begin to search for Bluetooth connections.
3. When your mobile phone finds the Uconnect system, select "Uconnect."



Bluetooth On/Uconnect Device

Complete The iPhone Pairing Procedure:

When prompted on the mobile phone, accept the connection request from Uconnect Phone.

NOTE:

Some mobile phones will require you to enter the PIN number.



Pairing Request

Select The iPhone's Priority Level

When the pairing process has successfully completed, the system will prompt you to choose whether or not this is your favorite mobile phone. Selecting "Yes" will make this mobile phone the highest priority. This mobile phone will take precedence over other paired mobile phones within range and will connect to the Uconnect system automatically when entering the vehicle. Only one mobile phone and/or one Bluetooth audio device can be connected to the Uconnect system at a time. If "No" is selected, simply select "Uconnect" from the mobile phone/audio device Bluetooth screen, and the Uconnect system will reconnect to the Bluetooth device.

Pair Your Android Device:

To search for available devices on your Bluetooth enabled Android Device:

1. Push the Menu button.
2. Select Settings.
3. Select Connections.
4. Turn Bluetooth setting to “On.”
 - Ensure the Bluetooth feature is enabled. Once enabled, the mobile phone will begin to search for Bluetooth connections.
5. Once your mobile phone finds the Uconnect system, select “Uconnect.”
 - You may be prompted by your mobile phone to download the phonebook, check “Do Not Ask Again” to automatically download the phonebook. This is so you can make calls by saying the name of your contact.



Bluetooth On/Uconnect Device

Complete The Android Pairing Procedure:

Confirm the passkey shown on the mobile phone matches the passkey shown on the Uconnect system then accept the Bluetooth pairing request.

NOTE:

Some mobile phones require the PIN to be entered manually, enter the PIN number shown on the Uconnect screen.

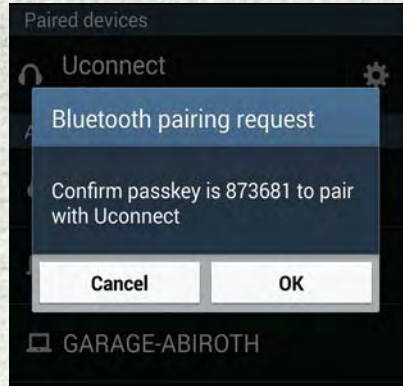

Pairing Request

Select The Android Mobile Phone's Priority Level

When the pairing process has successfully completed, the system will prompt you to choose whether or not this is your favorite mobile phone. Selecting “Yes” will make this mobile phone the highest priority. This mobile phone will take precedence over other paired mobile phones within range and will connect to the Uconnect system automatically when entering the vehicle. Only one mobile phone and/or one Bluetooth audio device can be connected to the Uconnect system at a time. If “No” is selected, simply select “Uconnect” from the mobile phone/audio device Bluetooth screen, and the Uconnect system will reconnect to the Bluetooth device.

You are now ready to make hands-free calls. Press the Uconnect “Phone” button  on your steering wheel to begin.

NOTE:

Refer to UconnectPhone.com website for additional information on mobile phone pairing and for a list of compatible phones.

Common Phone Commands (Examples)

- “Call John Smith”
- “Call John Smith mobile”
- “Dial 1 248 555 1212”
- “Redial”

Mute (Or Unmute) Microphone During Call

During a call, press the “Mute” button on the Phone main screen to mute and unmute the call.

Transfer Ongoing Call Between Handset And Vehicle

During an on-going call, press the “Transfer” button on the Phone main screen to transfer an on-going call between handset and vehicle.

Phonebook

The Uconnect system will automatically sync your phonebook from your paired phone, if this feature is supported by your phone. Phonebook contacts are updated each time that the phone is connected. If your phone book entries do not appear, check the settings on your phone. Some phones require you to enable this feature manually.

- Your phonebook can be browsed on the Uconnect system touchscreen, but editing can only be done on your phone. To browse, press the “Phone” button on the touchscreen, then the “Phonebook” button on the touchscreen.

Favorite phonebook entries can be saved as Favorites for quicker access. Favorites are shown at the top of the main phone screen.

Voice Command Tips

- Speaking complete names (i.e. Call John Doe vs. Call John) will result in greater system accuracy.
- You can “link” commands together for faster results. Say “Call John Doe, mobile,” for example.
- If you are listening to available voice command options, you do not have to listen to the entire list. When you hear the command that you need, push the  button on the steering wheel, wait for the beep and say your command.



Changing The Volume

- Start a dialogue by pushing the Phone button , then say a command for example - "Help".
- Use the radio VOLUME/MUTE rotary knob to adjust the volume to a comfortable level while the Uconnect system is speaking.

NOTE:

The volume setting for Uconnect is different than the audio system.

NOTE:

To access help, push the Uconnect Phone button  on the steering wheel and say "help." Push the Uconnect Phone Pickup button  or the VR button  and say "cancel" to cancel the help session.

Incoming Text Messages

After pairing your Uconnect system with a Bluetooth enabled mobile device with the Message Access Profile (MAP), the Uconnect system can announce a new incoming text message and read it to you over the vehicle's audio system.

NOTE:

Only incoming text messages received during the current ignition cycle can be viewed/read.

To enable incoming text messaging:

iPhone

1. Press the settings button on the mobile phone.
2. Select Bluetooth.
 - Ensure Bluetooth is enabled, and the mobile phone is paired to the Uconnect system.
3. Select  located under DEVICES next to Uconnect.
4. Turn "Show Notifications" to On.



Enable iPhone Incoming Text Messages

Android Devices

1. Push the Menu button on the mobile phone.
2. Select Settings.
3. Select Connections.
4. Turn "Show Notifications" to On.
 - A pop up will appear asking you to accept a request for permission to connect to your messages. Select "Don't ask again" and press OK.

NOTE:

All incoming text messages received during the current ignition cycle will be deleted from the Uconnect system when the ignition is turned to the Off position.

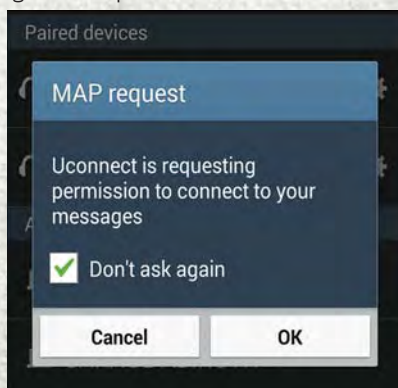

Enable Android Device Incoming Text Messages

Voice Text Reply (Not Compatible With iPhone)

NOTE:

Voice texting reply and voice texting features require a compatible mobile device enabled with Bluetooth Message Access Profile (MAP). iPhone, and some other smartphones, may not entirely support Bluetooth MAP. Visit UconnectPhone.com for the latest system and device compatibility.

- Due to the extremely large number of mobile phone manufacturers, your mobile device may not be listed. For further assistance, contact Uconnect Customer Care @ 1-877-855-8400 for U.S. residents or, 1-800-465-2001 (English) / 1-800-387-9983 (French) for Canadian residents.

Once your Uconnect system is paired with a compatible mobile device, the system can announce a new incoming text message, and read it to you over the vehicle audio system. You can reply to the message using Voice Recognition by selecting, or saying, one of the 18 pre-defined messages.

Here's How:

1. Push the Uconnect Phone button  and wait for the beep, then say "reply." Uconnect will give the following prompt: "Please say the message you would like to send."
2. Wait for the beep and say one of the pre-defined messages. (If you are not sure, you can say "help"). Uconnect will then read the pre-defined messages allowed.
3. As soon as you hear the message you would like to send, you can interrupt the list of prompts by pushing the Uconnect phone button and saying the phrase. Uconnect will confirm the message by reading it back to you.
4. Push the Phone button and say "Send."

PRE-DEFINED VOICE TEXT REPLY RESPONSES		
Yes.	Stuck in Traffic.	See you later.
No.	Start without me.	I'll be Late.
Okay.	Where are you?	I will be <5, 10, 15,...etc.> minutes late.
Call me.	Are you there yet?	
I'll call you later.	I need directions.	See you in <5, 10, 15,...etc.> of minutes.
I'm on my way.	Can't talk right now.	
I'm lost.		

NOTE:

To make the SMS voice reading function available, the SMS notification option on phone must be enabled; this option is usually available on the phone, in the Bluetooth connections menu for a device registered as Uconnect. After enabling this function on the mobile phone, it must be disconnected and reconnected with the Uconnect system in order to make it effective.

Helpful Tips And Common Questions To Improve Bluetooth Performance With Your Uconnect System

Mobile Phone won't reconnect to system after pairing:

- Set mobile phone to auto-connect or trusted device in mobile phone Bluetooth settings (Blackberry devices).
- Perform a factory reset on your mobile phone. Refer to your mobile phone manufacturer or cellular provider for instructions.
- Many mobile phones do not automatically reconnect after being restarted (hard reboot). Your mobile phone can still be connected manually. Close all applications that may be operating (refer to mobile phone manufacturer's instructions), and follow "Pairing (Wirelessly Connecting) Your Mobile Phone To The Uconnect System".

Mobile Phone won't pair to system:

- Perform a hard reset in the mobile phone by removing the battery (if removable — see your mobile phone's owner manual).
- Delete pairing history in mobile phone and Uconnect system; usually found in phone's Bluetooth connection settings.
- Verify you are selecting "Uconnect" in the discovered Bluetooth devices on your mobile phone.
- If your vehicle system generates a pin code the default is 0000.

Mobile Phonebook didn't download:

- Check "Do not ask again," then accept the "phonebook download" request on your mobile phone.
- Up to 2,000 contact names with six numbers per contact will transfer to the Uconnect 5.0/5.0N system phonebook.

Text messaging won't work:

- Check "Do not ask again," then accept the "connect to your messages" request on your mobile phone.
- Verify that your mobile phone has the Bluetooth feature (Message Access Profile).

Can't make a conference call:

- CDMA (Code-Division Multiple Access) carriers do not support conference calling. Refer to your mobile phone user's manual for further information.

Making calls while connected to AUX:

- Plugging in your mobile phone to AUX while connected to Bluetooth will disable Hands-Free Calling. Do not make calls while your mobile phone is plugged into the AUX jack.

STEERING WHEEL AUDIO CONTROLS

The steering wheel audio controls are located on the front surface of the steering wheel.

Right Switch

- Push the switch up or down to search for the next listenable station.

Left Switch

- Push the switch up or down to increase or decrease the volume.





Steering Wheel Audio Controls

- 1 — Left Switch
2 — Right Switch

ELECTRONIC VEHICLE INFORMATION CENTER (EVIC)

The EVIC features a driver interactive display that is located in the instrument cluster. Pushing the controls on the left side of the steering column allows the driver to select vehicle information and Personal Settings. Refer to “Programmable Features” in this guide for additional information.

- Push the **UP**  arrow button to scroll upward through the main menus (Menu, Outside Temperature Display, Trip Functions, Date, Time) and sub menus.
- Push the **DOWN**  arrow button to scroll downward through the main menus and sub menus.
- Push the **MODE** button for access to main menus, sub menus or to select a personal setting in the setup menu. Push and hold the **MODE** button for two seconds to reset features.
- Push and hold the **MODE** button for two seconds to reset displayed/selected features that can be reset.

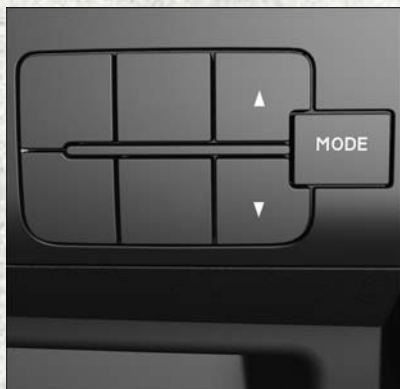





EVIC Controls

PROGRAMMABLE FEATURES

Programmable Features

The EVIC can be used to view or change the following settings:

- Push the **MODE** button to access the menu items then push the **UP**  or **DOWN**  arrow button to view the menu items listed below. Push the **MODE** button to enter the sub menus. Scroll through the settings using the **UP**  or **DOWN**  arrow buttons.
 - Menu
 - Outside Temperature Display
 - Trip Functions
 - Time
 - Date

Uconnect Customer Programmable Features

The Uconnect system allows you to access Customer Programmable feature settings such as Display, Clock & Date, Safety/Assistance, Lights, Doors & Locks, Audio, Phone/Bluetooth, SiriusXM Setup, Restore Default Settings and Clear Personal Data through buttons on the touchscreen.

To change a setting:

1. Push the **SETTINGS**  button located on the right side of the display.
2. Select a programmable feature you would like to adjust.
3. Make your selection highlighting the button.

Depending on the vehicles options, the following feature settings are available:

- Display
- Clock & Date
- Safety/Assistance
- Lights
- Doors & Locks
- Brakes
- Audio
- Phone/Bluetooth
- SiriusXM Setup
- Restore Settings
- Clear Personal Data

POWER OUTLETS

The front power outlet is located in the center console. It only operates with the ignition key at MAR/ON.

The power outlets are labeled with either a “key” or a “battery” symbol to indicate how the outlet is powered. Power outlets labeled with a “key” are powered when the ignition switch is in the MAR/ON position, while the outlets labeled with a “battery” are connected directly to the battery and powered at all times.

NOTE:

- Do not exceed the maximum power of 160 Watts (13 Amps) at 12 Volts. If the 160 Watt (13 Amp) power rating is exceeded, the fuse protecting the system needs to be replaced.
- Power outlets are designed for accessory plugs only. Do not insert any other object in the power outlet as this will damage the outlet and blow the fuse. Improper use of the power outlet can cause damage not covered by your New Vehicle Limited Warranty.



Front USB Port and Power Outlet

- 1 — USB Charge Only Port
- 2 — Front Power Outlet

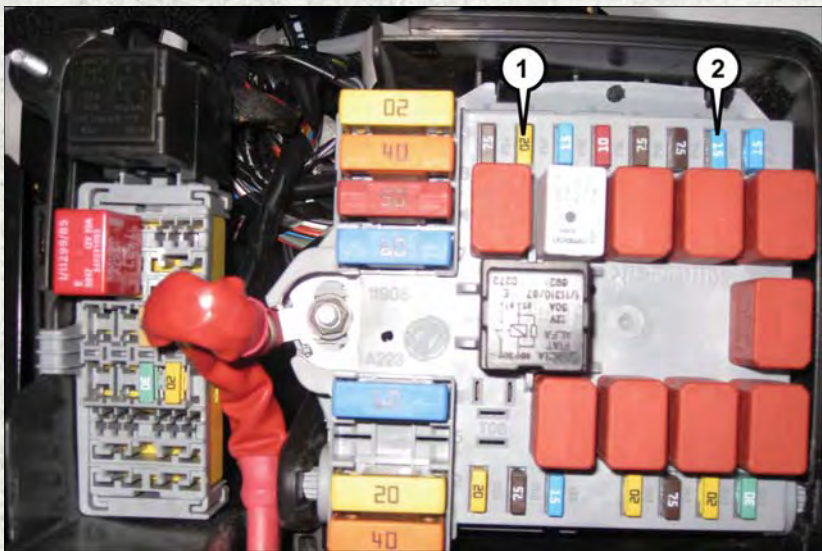

Power Outlet Fuses

- 1 — F14 Fuse 20 Amp Yellow Front Power Outlet
- 2 — F09 Fuse 15 Amp Blue Rear Power Outlet

TRAILER TOWING WEIGHTS (MAXIMUM TRAILER WEIGHT RATINGS)

NOTE:

For additional trailer towing information (maximum trailer weight ratings) refer to the following website addresses:

- ramtrucks.com/en/towing_guide/
- ramtruck.ca (Canada)
- rambodybuilder.com

RECREATIONAL TOWING (BEHIND MOTORHOME, ETC.)

Towing This Vehicle Behind Another Vehicle

Towing Condition	Wheels OFF the Ground	Gasoline Engine All Models	Diesel Engine All Models
Flat Tow	NONE	NOT ALLOWED	Trans In NEUTRAL
Dolly Tow	Front	OK	OK
	Rear	NOT ALLOWED	Trans In NEUTRAL
On Trailer	ALL	OK	OK

The manufacturer recommends towing your vehicle with all four wheels OFF the ground using a vehicle trailer.

Recreational Towing — Gasoline Engine All Models

Recreational towing is allowed ONLY if the front wheels are OFF the ground. This may be accomplished using a tow dolly or vehicle trailer. If using a tow dolly, follow this procedure:

1. Properly secure the dolly to the tow vehicle, following the dolly manufacturer's instructions.
2. Drive the front wheels onto the tow dolly.
3. Firmly apply the parking brake. Place the transmission in PARK.
4. Properly secure the front wheels to the dolly, following the dolly manufacturer's instructions.
5. Release the parking brake.

CAUTION!

- DO NOT flat tow any vehicle equipped with a conventional automatic transmission. Damage to the drivetrain will result. If these vehicles require towing, make sure all drive wheels are OFF the ground.
- Towing this vehicle in violation of the above requirements can cause severe transmission damage. Damage from improper towing is not covered under the New Vehicle Limited Warranty.

NOTE:

Automated Manual transmission (diesel) vehicles can also be flat towed (all four wheels on the ground) with the transmission in NEUTRAL. Ensure the transmission is in neutral (N) (by checking that the vehicle moves when pushed) and tow in the same way as a normal vehicle with a manual transmission.

DIESEL ENGINE BREAK-IN RECOMMENDATIONS

The diesel engine does not require a break-in period due to its construction. Normal operation is allowed, providing the following recommendations are followed:

- Warm up the engine before placing it under load.
- Do not operate the engine at idle for prolonged periods.
- Use the appropriate transmission gear to prevent engine lugging.
- Observe vehicle oil pressure and temperature indicators.
- Check the coolant and oil levels frequently.
- Vary throttle position at highway speeds when carrying or towing significant weight.

NOTE:

Light duty operation such as light trailer towing or no load operation will extend the time before the engine is at full efficiency. Reduced fuel economy and power may be seen at this time.

The engine oil installed in the engine at the factory is a high-quality energy conserving type lubricant. Oil changes should be consistent with anticipated climate conditions under which vehicle operations will occur. **NON-DETERGENT OR STRAIGHT MINERAL OILS MUST NEVER BE USED.**

DIESEL ENGINE STARTING PROCEDURES

Normal Starting Procedure

The gear selector must be in the NEUTRAL (N) position, and the brake pedal must be pressed, to allow engine cranking. Place the gear selector in NEUTRAL (N) and apply the brake pedal BEFORE turning the key to the START/AVV position; otherwise, the engine will not crank and the key must be cycled OFF, then back on, before cranking is allowed.

NOTE:

- Normal starting of either a cold or a warm engine is obtained without pumping or pressing the accelerator pedal.
- Observe the instrument panel cluster lights when starting the engine.

To start the engine follow the procedure below:

1. Press and hold the brake pedal.
2. Place the gear selector into the NEUTRAL (N) position while keeping the brake pedal depressed.
3. Turn the ignition switch to the ON/RUN/MAR position and watch the instrument panel cluster lights.

CAUTION!

If the “Generic Warning Light” remains on and a “Service Fuel Filter” message displays, DO NOT START engine before you drain the water from the fuel filter housing to avoid engine damage. Please see your authorized dealer for draining the fuel filter/water separator and fuel filter replacement.

4. After the Glow Plug light turns off, turn the ignition switch to the START/AVV position to start the engine. Do not press the accelerator during starting.
5. If you wish to stop the cranking of the engine prior to the engine starting, release the ignition key so that it turns back to the ON/RUN position.
6. Check that the oil pressure warning light has turned off.
7. Release the parking brake.

To start the engine if the transmission is faulty, run the “Delayed startup” procedure (see also "Instrument Cluster Messages" under "Automated Manual Transmission"):

1. Begin with the key in the OFF position.
2. Press and hold the brake pedal.
3. Turn the key to the START/AVV position and hold it there for at least seven seconds with the brake depressed. The engine will start, and the transmission will operate in recovery mode (maximum gear permitted = 3rd, automatic mode not available). If the engine does not start, contact your authorized dealer.

Extreme Cold Weather

This vehicle has three heating elements; one engine block heater (a resistance heater installed in the water jacket of the engine) and two transmission heaters (one resistance heater installed under the oil reservoir of the hydraulic actuation system and one on the differential cover of the transmission). They require a 110–115 Volt AC electrical outlet with a grounded, three-wire extension cord. Their use is recommended for environments that routinely fall below -10°F (-23°C). They should be used when the vehicle has not been running overnight or longer periods and should be plugged in two hours prior to start. Their use is required for cold starts with temperatures under -20°F (-29°C).

A 12 Volt heater built into the fuel filter housing aids in preventing fuel gelling. It is controlled by a built-in thermostat. This diesel pre-heat system improves engine starting and reduces the amount of white smoke generated by a warming engine.

NOTE:

- The engine is designed to work at an ambient temperature ranging from -22°F to + 122°F (-30°C to + 50°C). Rubber, pipes, timing belt cover and electronic devices are not designed to work out of this range.

- The engine and transmission block heater cord is a factory installed option. If your vehicle is not equipped, heater cords are available from your authorized MOPAR dealer.

In the case of LOW temperature after starting, the Automated Manual Transmission may not be able to engage first gear. In this case a message “Shift not allowed” appears. In this situation use the engine block heater.

Water In Fuel Message

If a Generic Warning Light appears in the cluster and a “Service Fuel Filter” message appears in Electronic Vehicle Information Center (EVIC), the fuel/water separator will need to be drained immediately to prevent engine damage. Please see your authorized dealer for draining the fuel filter/water separator and fuel filter replacement.

AUTOMATED MANUAL TRANSMISSION — DIESEL ONLY

The automated manual transmission is a conventional six-speed manual transmission with an electronically-controlled hydraulic system that controls the clutch and gear shifting. In forward gears, this transmission offers two modes of operation: MANUAL (M) mode (where the driver controls the transmission shifting), and Automatic mode (the DRIVE [D] position), where the electronic system controls the gear shifts. In either mode, there is no clutch pedal; the electronic system always controls the clutch operation.

NOTE:

- Engine torque will be interrupted briefly during the transmission upshifts, making these shifts more abrupt than with a typical automatic transmission. This is normal.
- Although transmission shifting is performed automatically, the vehicle will not “creep” when the brake pedal is released, and may in fact roll backwards on an incline. Leaving from a stop, the accelerator pedal must be pressed to transmit driving torque to the wheels.
- In Automatic Mode, the Automated Manual Transmission adapts the gear changing strategy evaluating the road condition such as slopes in the road.
- During low-speed driving conditions in first gear, vehicle momentum changes may feel exaggerated in response to changes in accelerator pedal position. This behavior is normal and is similar to other vehicles equipped with a manual transmission.

- At low speeds you may hear mechanical noises similar to a manual transmission as the transmission changes gears. These noises are normal and will not damage the transmission.
- Very aggressive driving may result in some clutch odor. A warning message will display in the EVIC if cool down actions are needed.
- Before and after the engine is started, you may hear a hydraulic pump for a short period of time. This noise is normal and will not damage the transmission.
- During extremely cold temperatures, the transmission will not operate if the oil temperature is -22°F (-30°C) or below. Allow the engine to idle briefly to warm the fluid. Normal operation will resume once the transmission temperature has risen to a suitable level.

WARNING!

You or others could be injured if you leave the vehicle unattended without fully applying the parking brake. The parking brake should always be applied when the driver is not in the vehicle, especially on an incline.

Shifting The Transmission

The transmission gear selector has REVERSE (R), NEUTRAL (N), DRIVE (D) and MANUAL (M) positions. In the MANUAL (M) position, the lever can be toggled rearward or forward (+/-) to upshift or downshift the transmission to the next gear. The actual transmission gear range (R, N, D, 1, 2, 3, 4, 5, or 6) is displayed in the EVIC whenever the engine is running.

When the key is turned OFF, the transmission remains in its previous gear position, regardless of the gear selector position. With key on/engine off, the display may indicate the gear selector position rather than the actual transmission gear position.

Although the gear selector can be moved freely the transmission will not actually shift unless the brake pedal is pressed, therefore the gear selector and display may not correspond to the actual transmission gear range. To shift the transmission to a particular gear range (with key on/engine off), press and hold the brake pedal, move the gear selector to NEUTRAL (N), then move the gear selector to the desired position.

To drive, start the engine, then move the gear selector from NEUTRAL (N) to the DRIVE (D) position for automatic mode, the MANUAL (M) position for manual mode or the REVERSE (R) position.

NOTE:

Only shift into DRIVE (D) or REVERSE (R) when the accelerator pedal is released and the vehicle is stopped. Be sure to keep your foot on the brake pedal when shifting between these gears.



Gear Selector

Instrument Cluster Messages

Messages will be displayed in the instrument cluster to alert the driver when certain unusual conditions occur. These messages are described below:

MESSAGE	DESCRIPTION
Transmission/Gearbox Fault (Red)	When the ignition key is turned to ON/RUN/MAR, the Transmission Fault Indicator light turns on and should go off after a few seconds. The Transmission Fault Indicator illuminates either steady or blinking (together with this message and a buzzer) to indicate a transmission fault. Contact your authorized dealer if the message continues to appear.
Reduce Gear Changes	This message indicates that the driver is operating the transmission incorrectly. Incorrect use (by the driver) could automatically activate a procedure for protecting the system. Contact you authorized dealer if the message continues to appear.
Manual Mode Not Available	MANUAL (M) mode is not available, due to a fault or other condition. Use the DRIVE (D) position to operate the vehicle. Contact your authorized dealer if the message continues to appear.
Automatic Mode Not Available	Automatic (DRIVE) mode is not available due to a fault or other condition. Use MANUAL (M) mode to operate the vehicle. Contact your authorized dealer if the message continues to appear.

MESSAGE	DESCRIPTION
Clutch Overheating	<p>This message appears, together with a buzzer, when the clutch overheats.</p> <p>In this situation, limit stop and go driving and gear shifts or if necessary stop the vehicle and turn the engine off to allow the clutch to cool.</p> <p>If the message continues to appear, contact your authorized dealer.</p> <p>To avoid clutch failure, do not use the accelerator to keep the vehicle at a standstill (for example holding on a hill); the clutch could be damaged by overheating. Use the brake pedal instead and operate the accelerator only when you are ready to drive away.</p>
Press Brake Pedal Delayed Startup	<p>This messages appears when the key is first turned ON, if the brake is fault and/or the gear selector is not in NEUTRAL (N). The gear selector must be in the NEUTRAL (N) position, and the brake pedal must be pressed, to allow engine cranking. Place the gear selector in NEUTRAL (N) and apply the brake pedal BEFORE turning the key to the START/AVV position; otherwise, the engine will not crank and the key must be cycled OFF, then back on, before cranking is allowed.</p>
Gear Not Available	<p>This message appears, along with a warning buzzer:</p> <ul style="list-style-type: none"> • When it is not possible to change gear due to a fault in the system. • When, due a fault in the system, it is only possible to engage 1st (1), 2nd (2), 3rd (3) or reverse (R). <p>Contact your authorized dealer if the message continues to appear.</p>
Shift Not Allowed	<p>This message appears, together with a warning buzzer, when the system will not allow a gear change requested by the driver (for example, that would cause engine overspeed or transmission damage).</p> <p>This message may also appear when starting the engine at low temperature. In this case the Automated Manual transmission isn't able to engage first gear, in this situation either use the engine block heater or allow the engine to idle in NEUTRAL (N) until the transmission has warmed.</p>
Press Brake Pedal And Try Again	<p>This message appears accompanied, in some cases, by a warning buzzer, if you attempt to change gear with the vehicle parked without pressing the brake pedal.</p> <p>To shift the transmission (with key on/engine off), press and hold the brake pedal, move the gear selector to NEUTRAL (N), then move the gear selector to the desired position.</p>
Shift To Neutral	<p>This message appears, together with a warning buzzer, when the gear selector must be moved to the NEUTRAL (N) position.</p> <p>When the gear selector is moved to NEUTRAL (N) the message on the display should go off.</p> <p>Contact your authorized dealer if the message continues to appear.</p>

MESSAGE	DESCRIPTION
Press Brake Pedal	This message is shown in the display together with an acoustic signal, when the brake pedal is not pressed during a starting attempt.
Press Brake Shift to N key to start	This message appears, after opening the driver's door, to remind you to press the brake pedal and shift the lever to NEUTRAL (N) to permit engine cranking.

Parking The Vehicle

To park safely, it is essential to engage MANUAL (1st) gear, DRIVE (D) or REVERSE (R) gear while your foot is on the brake pedal. Once MANUAL (1st) gear, DRIVE (D) or REVERSE (R) gear is displayed in the EVIC, turn the engine off and engage the parking brake. It is essential to wait until the gear engaged appears in the display before turning the engine off and releasing the brake pedal. Always remember to set your parking brake.

NOTE:

NEVER leave your vehicle with the gearbox in NEUTRAL (N) and always remember to fully apply your parking brake. Always remember to set the parking brake when the "Set Park Brake" message is displayed.

WARNING!

You or others could be injured if you leave the vehicle unattended without fully applying the parking brake. The parking brake should always be applied when the driver is not in the vehicle, especially on an incline.

EXHAUST REGENERATION

This engine meets all required EPA diesel engine emissions standards. To achieve these emissions standards, your vehicle is equipped with a state-of-the-art engine and exhaust system. These systems are seamlessly integrated into your vehicle and managed by the Powertrain Control Module (PCM). Additionally, your vehicle has the ability to alert you to additional maintenance required on your vehicle or engine. Refer to the following messages that may be displayed on your Electronic Vehicle Information Center (EVIC).

Exhaust System — Regeneration Required Now

This message Indicates that the Diesel Particulate Filter (DPF) reached 80% of its maximum storage capacity.

By simply driving your vehicle at highway speeds for up to 20 minutes, you can remedy the condition in the particulate filter system and allow your diesel engine and exhaust after-treatment system to cleanse the filter to remove the trapped PM and restore the system to normal operating condition.

Exhaust System — Regeneration In Process Exhaust Filter Full

This message indicates that the Diesel Particulate Filter (DPF) is self-cleaning. Maintain your current driving condition until regeneration is completed.

Exhaust System — Regeneration Completed

This message indicates that the Diesel Particulate Filter (DPF) self-cleaning is completed. If this message is displayed, you will hear one chime to assist in alerting you of this condition.

Exhaust Service Required — See Dealer Now

This message indicates regeneration has been disabled due to a system malfunction. The Powertrain control Module (PCM) will register a fault code and the instrument panel will display the Malfunction Indicator Light (MIL).

CAUTION!

See your authorized dealer, as damage to the exhaust system could occur soon with continued operation.

Exhaust Filter Full — Power Reduced See Dealer

The PCM derates the engine in order to limit the likelihood of permanent damage to the after-treatment system. If this condition is not corrected and a dealer service is not performed, extensive exhaust after-treatment damage can occur. Have your vehicle serviced by your local authorized dealer.

NOTE:

Failing to follow the oil change indicator, changing your oil and resetting the oil change indicator by 0 miles remaining will prevent the diesel exhaust filter from performing its cleaning routine. This will shortly result in a Malfunction Indicator Light (MIL) and reduced engine power. Only an authorized dealer will be able to correct this condition.

CAUTION!

See your authorized dealer, as damage to the exhaust system could occur with the exhaust filter full.

COOL-DOWN IDLE CHART

TURBO "COOL DOWN" CHART			
Driving Conditions	Load	Turbo Temp	Idle Time (in minutes) Before Shut Down
Stop and Go	Empty	Cool	Less than 1
Stop and Go	Medium	Warm	1
Highway Speeds	Medium	Warm	2
City Traffic	Max. GCWR	Warm	3
Highway Speeds	Max. GCWR	Warm	4
Uphill Grade	Max. GCWR	Hot	5

ADDING FUEL

The fuel cap is located behind the fuel filler door on the left side of the vehicle.

When the fuel nozzle "clicks" or shuts off, the fuel tank is full.

Tighten the fuel filler cap until you hear a "clicking" sound. This is an indication that the fuel filler cap is properly tightened.

Make sure that the fuel filler cap is tightened each time the vehicle is refueled.

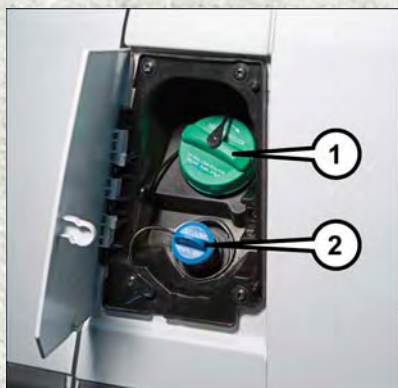

Fuel/DEF Fill Locations

- 1 — Diesel Fuel Fill Location
- 2 — Diesel Exhaust Fluid (DEF) Fill Location

CAUTION!

To avoid fuel spillage and overfilling, do not "top off" the fuel tank after filling.

WARNING!

A fire may result if fuel is pumped into a portable container that is on a truck bed. You could be burned. Always place fuel containers on the ground while filling.

DIESEL EXHAUST FLUID

Diesel Exhaust Fluid (DEF) sometimes known simply by the name of its active component, UREA – is a key component of selective catalytic reduction (SCR) systems, which help diesel vehicles meet stringent emission regulations. DEF is a liquid reducing agent that reacts with engine exhaust in the presence of a catalyst to convert smog-forming nitrogen oxides (NOx) into harmless nitrogen and water vapor.

Your vehicle is equipped with a Selective Catalytic Reduction system in order to meet the very stringent diesel emissions standards required by the Environmental Protection Agency. Selective Catalytic Reduction (SCR) is the first and only technology in decades to be as good for the environment as it is good for business and vehicle performance.

The purpose of the SCR system is to reduce levels of NOx (oxides of nitrogen emitted from engines) that are harmful to our health and the environment to an almost near-zero level. Small quantities of Diesel Exhaust Fluid (DEF) are injected into the exhaust upstream of a catalyst where, when vaporized, convert smog-forming nitrogen oxides (NOx) into harmless nitrogen (N₂) and water vapor (H₂O), two natural components of the air we breathe. You can operate with the comfort that your vehicle is contributing to a cleaner, healthier world environment for this and generations to come.

System Overview

This vehicle is equipped with a Diesel Exhaust Fluid (DEF) injection system and a Selective Catalytic Reduction (SCR) catalyst to meet the emission requirements.

The DEF injection system consists of the following components:

- DEF tank
- DEF pump
- DEF injector
- Electronically-heated DEF lines
- NOx sensors
- Temperature sensors
- SCR catalyst

The DEF injection system and SCR catalyst enable the achievement of diesel emissions requirements; while maintaining outstanding fuel economy, drivability, torque and power ratings.

NOTE:

- Your vehicle is equipped with a DEF injection system. You may occasionally hear an audible clicking noise. This is normal operation.
- The DEF pump will run for a period of time after engine shutdown to purge the DEF system. This is normal operation.

Adding Diesel Exhaust Fluid

The DEF low level message (located in the EVIC) will display when the DEF level is low. Completely fill the DEF tank through the diesel exhaust fluid fill location (located behind the fuel door) at every maintenance interval or before if prompted by the Electronic Vehicle Information Center (EVIC).

NOTE:

- Driving conditions (altitude, vehicle speed, load, etc.) will effect the amount of DEF that is used in your vehicle.
- Since DEF will begin to freeze at 12°F (-11°C), your vehicle is equipped with an automatic DEF heating system. This allows the DEF injection system to operate properly at temperatures below 12°F (-11°C). If your vehicle is not in operation for an extended period of time with temperatures below 12°F (-11°C), the DEF in the tank may freeze. If the tank is overfilled and freezes, it could be damaged. Therefore, do not overfill the DEF tank. Extra care should be taken when filling with portable containers to avoid overfilling. Note the level of the DEF gauge in your instrument cluster. On pickup applications, you may safely add a maximum of 2 gallons (7.5 liters) of DEF from portable containers when your DEF gauge is reading ½ full.

DEF Fill Procedure

- Remove cap from DEF tank (located behind the fuel door on drivers side of the vehicle).
- Insert DEF container or fill nozzle into DEF fill location and fill DEF tank.
- Reinstall cap onto DEF tank.

Refer to your Owner's Manual on the DVD for further details.

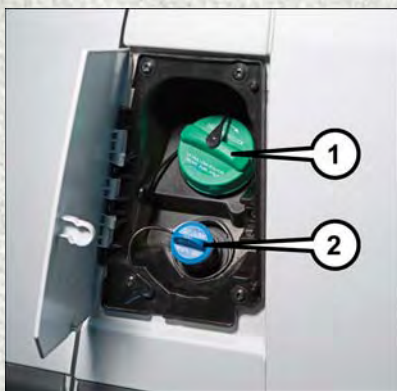

Fuel/DEF Fill Locations

- 1 — Diesel Fuel Fill Location
- 2 — Diesel Exhaust Fluid (DEF) Fill Location

CAUTION!

- To avoid DEF spillage and overfilling, do not “top off” the DEF tank after filling.
- When DEF is spilled, clean the area immediately with water or a mild solvent.
- **DO NOT OVERFILL.** DEF will freeze below 12 degrees F (-11 degrees C). The DEF system is designed to work in temperatures below the DEF freezing point, however, if the tank is overfilled and freezes, the system could be damaged.

Diesel Exhaust Fluid (DEF) Messages

- First low level warning will be given at around 500 miles (804 km), which is determined by current consumption rate. DEF Low level lamp icon and display message for refill will be displayed at dashboard. DEF Low level Lamp will stay on until a DEF refill is detected (minimum 1 gallon [3.7 liters]).
- To correct this condition it will be necessary to fully refill the DEF tank.
- If refill is not performed, a second low level warning will be given about 200 (321 km) miles are left to empty the DEF Tank.
- Display message of speed limitation with DEF Low Level lamp will be there on dashboard.
- The driver will be also be informed about the speed restriction when approximately 150 and 125 miles (241 and 201 km) are left to empty the DEF Tank.
- When 100 miles (160 km) are left to empty the DEF Tank, a continuous message display with chimes will be there on dashboard.
- When count down is over (0 miles left), continuous message “Speed limited at refuel or next engine start” is shown on EVIC. In this case if an engine restart or a diesel refuel action in engine-on condition is performed, vehicle’s speed will be limited to 5 mph (8 km/h) and continuous message “Speed limited DEF low” is shown on EVIC.
- The restriction becomes inactive as soon as the DEF refill event is detected (minimum quantity to be added is 1 gallon [3.7 liters]).

WHAT TO DO IN EMERGENCIES

ROADSIDE ASSISTANCE

Dial toll-free 1-800-521-2779 for U.S. Residents or 1-800-363-4869 for Canadian Residents.

- Provide your name, vehicle identification number, license plate number, and your location, including the telephone number from which you are calling.
- Briefly describe the nature of the problem and answer a few simple questions.
- You will be given the name of the service provider and an estimated time of arrival. If you feel you are in an “unsafe situation”, please let us know. With your consent, we will contact local police or safety authorities.

INSTRUMENT CLUSTER WARNING LIGHTS

– Low Fuel Warning Light

This warning light indicates when the fuel level reaches approximately 1.5 gal (5.8 L). This light will turn on and a single chime will sound.

– Battery Charge Warning Light

This light illuminates when the battery is not charging properly. If the battery charge warning light remains on, it means that the vehicle is experiencing a problem with the charging system.

We recommend you do not continue driving if the battery charge warning light is on. Have the vehicle serviced immediately.

– Oil Pressure Warning Light

This light indicates low engine oil pressure. If the light turns on while driving, stop the vehicle and shut off the engine as soon as possible. A chime will sound when this light turns on.

We recommend you do not operate the vehicle or engine damage will occur. Have the vehicle serviced immediately.

– Engine Temperature Warning Light

This light warns of an overheated engine condition and is located next to the “H” hot indicator portion of the temperature gauge.

This light warns of an overheated engine condition. As engine coolant temperatures rise and the gauge approaches H, this indicator will illuminate and a single chime will sound after reaching a set threshold. Further overheating will cause the temperature gauge to pass H. A continuous chime will occur until the engine is allowed to cool or the four minutes duration is expired, whichever comes first.

We recommend that you do not operate the vehicle or engine damage will occur. Have the vehicle serviced immediately.

WHAT TO DO IN EMERGENCIES

WARNING!

A hot engine cooling system is dangerous. You or others could be badly burned by steam or boiling coolant.

– Anti-Lock Brake (ABS) Light

This light monitors the Anti-Lock Brake System (ABS).

If the light is not on during startup, stays on, or turns on while driving we recommend you contact the nearest authorized dealer and have the vehicle serviced immediately.

– Air Bag Warning Light

If the light is not on during startup, stays on, or turns on while driving have the vehicle serviced by an authorized dealer immediately.

– Electronic Throttle Control (ETC) Indicator Light

This light informs you of a problem with the system.

If a problem is detected, the light will come on while the engine is running. Cycle the ignition when the vehicle has completely stopped and the gear selector is placed in the PARK position; the light should turn off.

If the light remains lit with the engine running, your vehicle will usually be drivable. However, see an authorized dealer immediately. If the light is flashing when the engine is running, immediate service is required, and you may experience reduced performance, an elevated/rough idle or engine stall, and your vehicle may require towing.

– Tire Pressure Monitoring System (TPMS) Light

Each tire, including the spare (if provided), should be checked monthly when cold and inflated to the inflation pressure recommended by the vehicle manufacturer on the vehicle placard or tire inflation pressure label. (If your vehicle has tires of a different size than the size indicated on the vehicle placard or tire inflation pressure label, you should determine the proper tire inflation pressure for those tires).

As an added safety feature, your vehicle has been equipped with a tire pressure monitoring system (TPMS) that illuminates a low tire pressure telltale when one or more of your tires is significantly under-inflated. Accordingly, when the low tire pressure telltale illuminates, you should stop and check your tires as soon as possible and inflate them to the proper pressure. Driving on a significantly under-inflated tire causes the tire to overheat and can lead to tire failure. Under-inflation also reduces fuel efficiency and tire tread life and may affect the vehicle's handling and stopping ability.

WHAT TO DO IN EMERGENCIES

IF THE LIGHT STARTS FLASHING INDICATING A LOW TIRE PRESSURE, ADJUST THE AIR PRESSURE IN THE LOW TIRE TO THE AIR PRESSURE SHOWN ON THE VEHICLE PLACARD OR TIRE INFLATION PRESSURE LABEL LOCATED ON THE DRIVER'S DOOR.

NOTE:

AFTER INFLATION, THE VEHICLE MAY NEED TO BE DRIVEN FOR 20 MINUTES BEFORE THE FLASHING LIGHT WILL TURN OFF.

Please note that the TPMS is not a substitute for proper tire maintenance, and it is the driver's responsibility to maintain correct tire pressure, even if under-inflation has not reached the level to trigger illumination of the TPMS low tire pressure telltale.

Your vehicle has also been equipped with a TPMS malfunction indicator to indicate when the system is not operating properly. The TPMS malfunction indicator is combined with the low tire pressure telltale.

When the system detects a malfunction, the telltale will flash for approximately one minute and then remain continuously illuminated. This sequence will continue upon subsequent vehicle start-ups as long as the malfunction exists. When the malfunction indicator is illuminated, the system may not be able to detect or signal low tire pressure as intended. TPMS malfunctions may occur for a variety of reasons, including the installation of replacement or alternate tires or wheels on the vehicle that prevent the TPMS from functioning properly. Always check the TPMS malfunction telltale after replacing one or more tires or wheels on your vehicle to ensure that the replacement or alternate tires and wheels allow the TPMS to continue to function properly.

NOTE:

Tire pressures change by approximately 1 psi (7 kPa) per 12° F (7° C) of air temperature change. Keep this in mind when checking tire pressure inside a garage, especially in the Winter. Example: If garage temperature is 68°F (20°C), and the outside temperature is 32°F (0°C), then the cold tire inflation pressure should be increased by 3 psi (21 kPa), which equals 1 psi (7 kPa) for every 12°F (7°C) for this outside temperature condition.

CAUTION!

The TPMS has been optimized for the original equipment tires and wheels. TPMS pressures and warning have been established for the tire size equipped on your vehicle. Undesirable system operation or sensor damage may result when using replacement equipment that is not of the same size, type, and/or style. Aftermarket wheels can cause sensor damage. Do not use tire sealant from a can, or balance beads if your vehicle is equipped with a TPMS, as damage to the sensors may result.

WHAT TO DO IN EMERGENCIES

– Seat Belt Reminder Light

When the ignition switch is first turned to the ON/RUN position, this light will turn on for four to eight seconds as a bulb check. During the bulb check, if the driver's seat belt is unbuckled, a chime will sound. After the bulb check or when driving, if the driver or front passenger seat belt remains unbuckled, the Seat Belt Indicator Light will flash or remain on continuously. Refer to "Seat Belt Systems" in "Things To Know Before Starting" in your Owner's Manual on the DVD for further information.

BRAKE – Brake Warning Light

This light monitors various brake functions, including brake fluid level and parking brake application. If the brake light turns on, it may indicate that the parking brake is applied, that the brake fluid level is low, or that there is a problem with the brake system master cylinder reservoir.

If the light remains on when the parking brake has been disengaged, and the fluid level is at the full mark on the master cylinder reservoir, it indicates a possible brake hydraulic system malfunction or that a problem with the Brake Booster has been detected by the Anti-Lock Brake System (ABS)/Electronic Stability Control (ESC) system. In this case, the light will remain on until the condition has been corrected. If the problem is related to the brake booster, the ABS pump will run when applying the brake, and a brake pedal pulsation may be felt during each stop.

The dual brake system provides a reserve braking capacity in the event of a failure to a portion of the hydraulic system. A leak in either half of the dual brake system is indicated by the Brake Warning Light, which will turn on when the brake fluid level in the master cylinder has dropped below a specified level. The light will remain on until the cause is corrected.

Vehicles equipped with the Anti-Lock Brake System (ABS) are also equipped with Electronic Brake Force Distribution (EBD). In the event of an EBD failure, the Brake Warning Light will turn on along with the ABS Light. Immediate repair to the ABS system is required.

Operation of the Brake Warning Light can be checked by turning the ignition switch from the OFF position to the ON/RUN position. The light should illuminate for approximately two seconds. The light should then turn off unless the parking brake is applied or a brake fault is detected. If the light does not illuminate, have the light inspected by an authorized dealer.

The light also will turn on when the parking brake is applied with the ignition switch in the ON/RUN position.

NOTE:

This light shows only that the parking brake is applied. It does not show the degree of brake application.

WHAT TO DO IN EMERGENCIES

WARNING!

Driving a vehicle with the red brake light on is dangerous. Part of the brake system may have failed. It will take longer to stop the vehicle. You could have a collision. Have the vehicle checked immediately.



– Malfunction Indicator Light (MIL)

Certain conditions, such as a loose or missing gas cap, poor fuel quality, etc., may illuminate the MIL after engine start. The vehicle should be serviced if the light stays on through several typical driving cycles. In most situations, the vehicle will drive normally and not require towing.

If the MIL flashes when the engine is running, serious conditions may exist that could lead to immediate loss of power or severe catalytic converter damage. We recommend you do not operate the vehicle. Have the vehicle serviced immediately.



– Generic Warning Light

The Generic Warning Light will illuminate if any of the following conditions occur: Oil Change Request, Engine Oil Pressure Sensor Failure, External Light Failure, Fuel Cut-Off Intervention, Fuel Cut-Off Not Available, Parking Sensor Failure, Engine Oil Minimum Level, Engine Oil Minimum Level Sensor Fail.

INSTRUMENT CLUSTER INDICATOR LIGHTS



– Turn Signal Indicator

The arrows will flash with the exterior turn signals when the turn signal lever is operated. A tone will chime, and a EVIC message will appear if either turn signal is left on for more than 1 mile (1.6 km).

NOTE:

If either indicator flashes at a rapid rate, check for a defective outside light bulb.



– High Beam Indicator

Indicates that headlights are on high beam.



– Front Fog Light Indicator

This indicator will illuminate when the front fog lights are on.



– Park/Headlight ON Indicator

This indicator will illuminate when the park lights or headlights are turned on.

WHAT TO DO IN EMERGENCIES

– Vehicle Security Light

This light will flash rapidly for approximately 15 seconds when the vehicle security alarm is arming. The light will flash at a slower speed continuously after the alarm is set. The security light will also come on for about three seconds when the ignition is first turned on.

– Electronic Speed Control SET Indicator

This indicator will illuminate when the cruising speed has been set.

– Door Open Indicator

This indicator will illuminate when a door(s) is left open and not fully closed.

– Electronic Stability Control (ESC) OFF Indicator Light

This light indicates the ESC system has been turned off by the driver.

ESC – Electronic Stability Control (ESC) Activation / Malfunction Indicator Light

The “ESC Activation/Malfunction Indicator Light” in the instrument cluster will come on for four seconds when the ignition switch is turned to the ON/RUN position. If the “ESC Activation/Malfunction Indicator Light” comes on continuously with the engine running, a malfunction has been detected in the ESC system. If this light remains on, see your authorized dealer as soon as possible to have the problem diagnosed and corrected.

NOTE:

- The “ESC Off Indicator Light” and the “ESC Activation/Malfunction Indicator Light” come on momentarily each time the ignition switch is turned to ON/RUN.
- Each time the ignition is turned to ON/RUN, the ESC system will be ON even if it was turned off previously.
- ESC Activation/Malfunction Light can blink during a ESC or TC intervention.

– Windshield Washer Fluid Low Indicator

This indicator will illuminate when the windshield washer fluid is low.

WHAT TO DO IN EMERGENCIES

IF YOUR ENGINE OVERHEATS

In any of the following situations, you can reduce the potential for overheating by taking the appropriate action:

- On the highways — slow down.
- In city traffic — while stopped, shift the transmission to NEUTRAL, but do not increase engine idle speed.

NOTE:

There are steps that you can take to slow down an impending overheat condition:

- If your air conditioner (A/C) is on, turn it off. The A/C system adds heat to the engine cooling system and turning the A/C off can help remove this heat.
- You can also turn the temperature control to maximum heat, the mode control to floor and the blower control to high. This allows the heater core to act as a supplement to the radiator and aids in removing heat from the engine cooling system.

CAUTION!

Driving with a hot cooling system could damage your vehicle. If the temperature gauge reads HOT (H), pull over and stop the vehicle. Idle the vehicle with the air conditioner turned off until the pointer drops back into the normal range. If the pointer remains on HOT (H), and you hear continuous chimes, turn the engine off immediately, and call for service.

WARNING!

You or others can be badly burned by hot engine coolant (antifreeze) or steam from your radiator. If you see or hear steam coming from under the hood, do not open the hood until the radiator has had time to cool. Never try to open a cooling system pressure cap when the radiator or coolant bottle is hot.

WHAT TO DO IN EMERGENCIES

JACKING AND TIRE CHANGING

WARNING!

- Do not attempt to change a tire on the side of the vehicle close to moving traffic. Pull far enough off the road to avoid the danger of being hit when operating the jack or changing the wheel.
- Being under a jacked-up vehicle is dangerous. The vehicle could slip off the jack and fall on you. You could be crushed. Never put any part of your body under a vehicle that is on a jack. If you need to get under a raised vehicle, take it to a service center where it can be raised on a lift.
- Never start or run the engine while the vehicle is on a jack.
- The jack is designed to be used as a tool for changing tires only. The jack should not be used to lift the vehicle for service purposes. The vehicle should be jacked on a firm level surface only. Avoid ice or slippery areas.

Jack And Tools Location

The jack and jack tools are stored under the front passenger seat.

To release the jack kit for its storage location, you must push down and turn the lock knob 1/4 turn counter clockwise to the unlock position.



Jack Kit Location

WHAT TO DO IN EMERGENCIES

CAUTION!

Do not force lock knob over limit. Damage to lock knob may occur.



Lock Knob

- 1 — Unlock Position
- 2 — Lock Position

WHAT TO DO IN EMERGENCIES

To open the jack kit container you must push the containers release to separate the top and bottom.



Container Release



Jacking Tools

- 1 — Jack
 - 2 — Reversible Tool
 - 3 — Tool Handle
 - 4 — Winch Extension
 - 5 — Tow Eye
 - 6 — Wrench Handle
 - 7 — Lug Bolt Adaptor
-

WHAT TO DO IN EMERGENCIES

Removing The Spare Tire

1. Remove the spare tire before attempting to jack up the vehicle. Attach the lug bolt adapter to the winch extension and insert it into the winch mechanism.

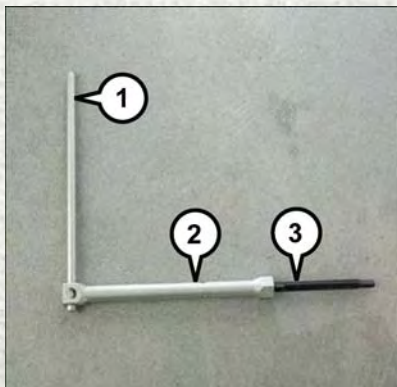

Jack Tools

- 1 — Wrench Handle
- 2 — Lug Bolt Adapter
- 3 — Winch Extension



Winch Location

WHAT TO DO IN EMERGENCIES

The winch mechanism is located under the rear of the vehicle to the right of the spare tire.



Winch Location

2. Rotate the wheel wrench handle counterclockwise until the spare tire is on the ground with enough cable slack to allow you to pull it out from under the vehicle.

NOTE:

The winch mechanism is designed for use with the winch extension tube only. Use of an air wrench or other power tools is not recommended and can damage the winch.



Winch Extension

WHAT TO DO IN EMERGENCIES

3. Pull the spare tire out from under the vehicle to gain access to the spare tire retainer.



Lowering Spare Tire



Spare Tire

4. Remove the retainer nut prior to removing the retainer from the wheel.



Retainer Nut

WHAT TO DO IN EMERGENCIES

5. Lift the spare tire with one hand to give clearance to tilt the retainer at the end of the cable.



Lifting Spare Tire

6. Pull the retainer through the center of the wheel.

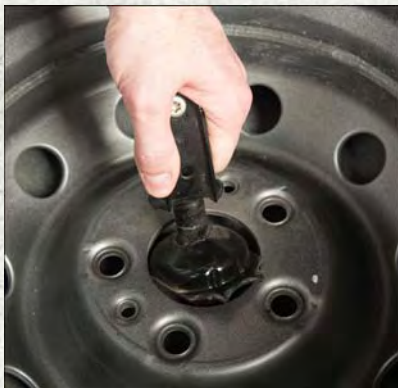

Retainer

WHAT TO DO IN EMERGENCIES

Preparations

1. Park the vehicle on a firm, level surface. Avoid ice or slippery areas.

WARNING!

Do not attempt to change a tire on the side of the vehicle close to moving traffic, pull far enough off the road to avoid the danger of being hit when operating the jack or changing the wheel.

2. Turn on the Hazard Warning flasher.
3. Set the parking brake firmly.
4. Set an automatic transmission in PARK; a manual transmission in REVERSE.
5. Turn the ignition OFF.
6. Block the front and rear of the wheel diagonally opposite of the jacking position. For example, if changing the right front tire, block the left rear wheel.

NOTE:

Passengers should not remain in the vehicle when the vehicle is being jacked.

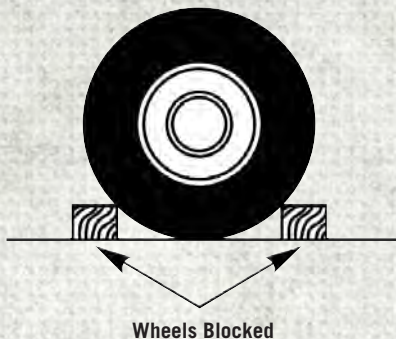

WHAT TO DO IN EMERGENCIES

Jacking Instructions

WARNING!

Carefully follow these tire changing warnings to help prevent personal injury or damage to your vehicle:

- Always park on a firm, level surface as far from the edge of the roadway as possible before raising the vehicle.
- Turn on the Hazard Warning flashers.
- Block the wheel diagonally opposite the wheel to be raised.
- Set the parking brake firmly and set an automatic transmission in PARK; a manual transmission in REVERSE.
- Never start or run the engine with the vehicle on a jack.
- Do not let anyone sit in the vehicle when it is on a jack.
- Do not get under the vehicle when it is on a jack. If you need to get under a raised vehicle, take it to a service center where it can be raised on a lift.
- Only use the jack in the positions indicated and for lifting this vehicle during a tire change.
- If working on or near a roadway, be extremely careful of motor traffic.
- To assure that spare tires, flat or inflated, are securely stowed, spares must be stowed with the valve stem facing the ground.



Jack Warning Label

CAUTION!

Do not attempt to raise the vehicle by jacking on locations other than those indicated in the Jacking Instructions for this vehicle.



Assembled Jack

WHAT TO DO IN EMERGENCIES

1. Loosen (but do not remove) the wheel lug bolts by turning them to the left one turn while the wheel is still on the ground.
2. There are two jack engagement locations on each side of the vehicle body.

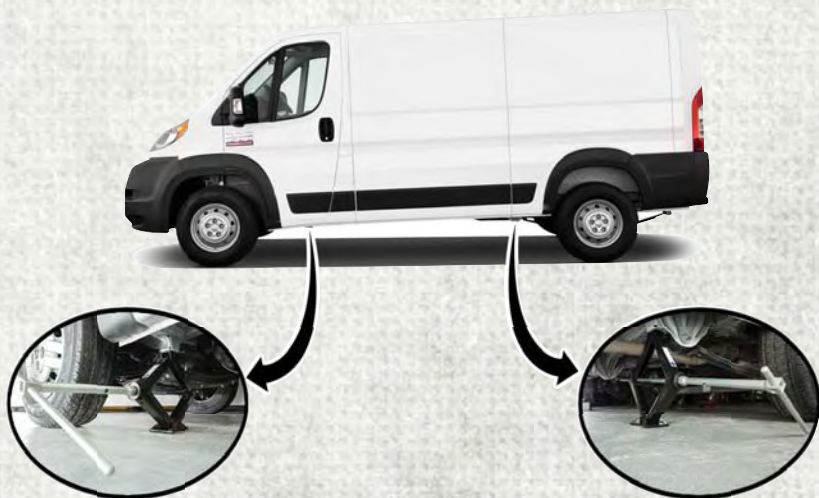

Jacking Engagement Locations

CAUTION!

Do not attempt to raise the vehicle by jacking on locations other than those indicated.

NOTE:

The rear jacking location is located in front of the rear tire and in front of the leaf spring mount.



Rear Jacking Location

WHAT TO DO IN EMERGENCIES

NOTE:

The front jacking location is located behind the front tire and in front of the driver/passenger door.



Front Jacking Location

WARNING!

Being under a jacked-up vehicle is dangerous. The vehicle could slip off the jack and fall on you. You could be crushed. Never get any part of your body under a vehicle that is on a jack. If you need to get under a raised vehicle, take it to a service center where it can be raised on a lift.

3. Place the wrench handle and lug bolt adapter on the jack screw and turn to the right until the jack head is properly engaged in the described location. **Do not raise the vehicle until you are sure the jack is securely engaged.**
4. Raise the vehicle by turning the jack screw to the right, using the wrench handle and lug bolt adapter. Raise the vehicle only until the tire just clears the surface and enough clearance is obtained to install the spare tire. Minimum tire lift provides maximum stability.

WARNING!

Raising the vehicle higher than necessary can make the vehicle less stable. It could slip off the jack and hurt someone near it. Raise the vehicle only enough to remove the tire.

5. Remove the wheel lug bolts. For vehicles with wheel covers, remove the cover from the wheel by hand. Do not pry the wheel cover off. Then pull the wheel off the hub.
6. Install the spare tire. Lightly tighten the wheel lug bolts.

WHAT TO DO IN EMERGENCIES

CAUTION!

Be sure to mount the spare tire with the valve stem facing outward. The vehicle could be damaged if the spare tire is mounted incorrectly.



Mounting Spare Tire

WARNING!

To avoid the risk of forcing the vehicle off the jack, do not tighten the wheel nuts fully until the vehicle has been lowered. Failure to follow this warning may result in personal injury.

NOTE:

Do not install the wheel cover on the spare tire.

7. Lower the vehicle by turning the jack screw to the left.
8. Refer to "Torque Specifications" in the Owner's Manual on DVD for proper wheel lug bolt torque.
9. Lower the jack to its fully-closed position.
10. Stow the damaged wheel/spare tire with the cable and wheel spacer before driving the vehicle.

WHAT TO DO IN EMERGENCIES

11. Install the winch extension and rotate the wrench handle clockwise until the winch mechanism indication window turns yellow and the operator hears “3 clicks” from the device to show the wheel is properly stowed under the vehicle.



Winch Mechanism Properly Engaged (Yellow DOT Will Appear In The Winch Indication Window)



Winch Mechanism NOT Properly Engaged (Black Window Will Appear)

CAUTION!

In the case that the yellow dot does not appear in the winch mechanism window refer to step 11 above, the operator should repeat the spare tire installation procedure. If the yellow dot does not appear in the winch indication window, place and secure the damaged wheel into the vehicle and seek dealer assistance to the winch mechanism.

WHAT TO DO IN EMERGENCIES

12. Stow the jack, jack handle and winch handle tools back in the storage compartment.

WARNING!

A loose tire or jack thrown forward in a collision or hard stop could endanger the occupants of the vehicle. Always stow the jack parts and the spare tire in the places provided. Have the deflated (flat) tire repaired or replaced immediately.

13. Check the spare tire pressure as soon as possible. Correct the tire pressure, as required.

For vehicles with aluminum wheels:

1. Remove the adapter bracket and bolts from the storage bag in the glove compartment.
2. Take the retainer and position it inside the circular bracket.

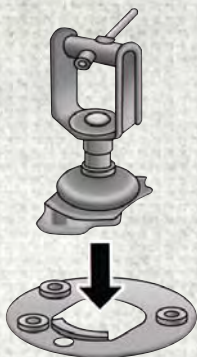

Adapter/Bracket Union

WHAT TO DO IN EMERGENCIES

3. Tighten the knob on the bolt to secure it to the bracket.

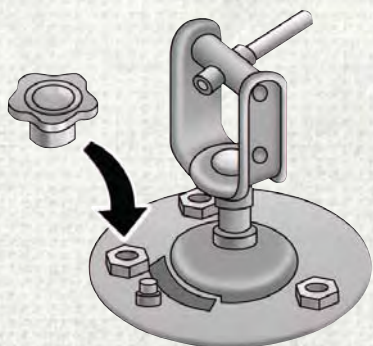

Securing The Bracket

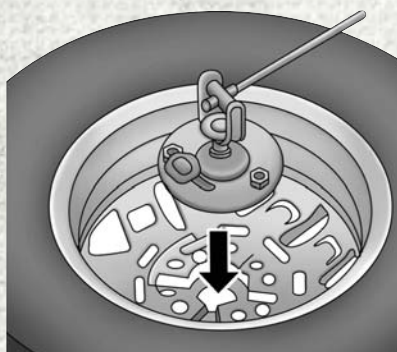

Alloy Wheel Mounting

WHAT TO DO IN EMERGENCIES

4. Position the tire vertically and lay the mounted adapter on the inner part of the rim. Using the supplied bolts, fasten the wheel to the adapter using the bolt install wrench. Tighten the bolts with the wrench extension and wrench handle.
5. **Follow the steps above for proper spare tire stowage.**

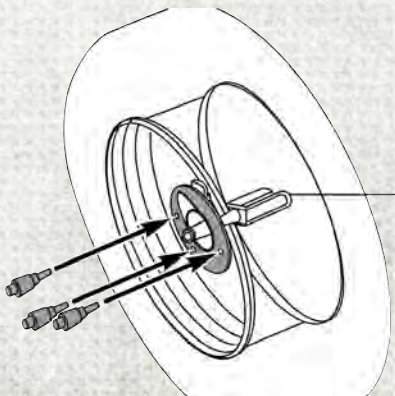

Wheel/Bolts Attaching To Mounting Bracket

Wheel Covers

CAUTION!

Use a back-and-forth motion to remove the hub cap. Do not use a twisting motion when removing the hub cap, damage to the hub cap finish may occur.

The wheel covers on the vehicle are held in place by the wheel lug bolts and can be removed after the wheel lug bolts are taken off.

JUMP-STARTING PROCEDURES

If your vehicle has a discharged battery it can be jump-started using a set of jumper cables and a battery in another vehicle or by using a portable battery booster pack. Jump-starting can be dangerous if done improperly so please follow the procedures in this section carefully.

NOTE:

When using a portable battery booster pack follow the manufacturer's operating instructions and precautions.

CAUTION!

Do not use a portable battery booster pack or any other booster source with a system voltage greater than 12 Volts or damage to the battery, starter motor, alternator or electrical system may occur.

WHAT TO DO IN EMERGENCIES

WARNING!

Do not attempt jump-starting if the battery is frozen. It could rupture or explode and cause personal injury.

Preparations For Jump-Start

The vehicle's jump starting remote posts are located under the hood, in the engine compartment on the driver's side.

The Remote Positive (+) Post is covered with a protective cap located on the side of the Front Power Distribution Center.

The Remote Negative (-) Post is located on the core support closest to the front of the vehicle.

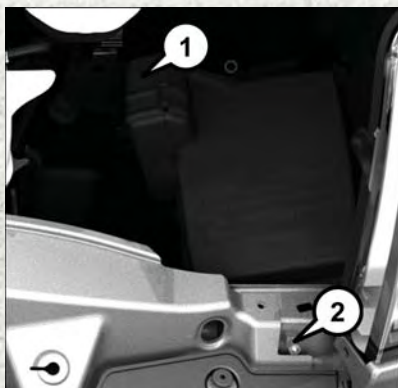

Remote Battery Posts

- 1 — Remote Positive (+) Jump Starting Post
- 2 — Remote Negative (-) Jump Starting Post

WARNING!

- Take care to avoid the radiator cooling fan whenever the hood is raised. It can start anytime the ignition switch is ON. You can be injured by moving fan blades.
- Remove any metal jewelry such as rings, watch bands and bracelets that could make an inadvertent electrical contact. You could be seriously injured.
- Batteries contain sulfuric acid that can burn your skin or eyes and generate hydrogen gas which is flammable and explosive. Keep open flames or sparks away from the battery.

WHAT TO DO IN EMERGENCIES

1. Set the parking brake, shift the automatic transmission into PARK and turn the ignition to the OFF position.
2. Turn off the heater, radio, and all unnecessary electrical accessories.
3. If using another vehicle to jump-start the battery, park the vehicle within the jumper cables reach, set the parking brake and make sure the ignition is OFF.

WARNING!

Do not allow vehicles to touch each other as this could establish a ground connection and personal injury could result.

Jump-Starting Procedure

WARNING!

Failure to follow this jump-starting procedure could result in personal injury or property damage due to battery explosion.

CAUTION!

Failure to follow these procedures could result in damage to the charging system of the booster vehicle or the discharged vehicle.

Connecting The Jumper Cables

1. Connect the positive (+) end of the jumper cable to the remote positive (+) post of the discharged vehicle.

NOTE:

The remote positive (+) post is located in the engine compartment on the driver's side under the cover of the Front Power Distribution Center.

2. Connect the opposite end of the positive (+) jumper cable to the positive (+) post of the booster battery.
3. Connect the negative end (-) of the jumper cable to the negative (-) post of the booster battery.
4. Connect the opposite end of the negative (-) jumper cable to the remote negative (-) post of the discharged vehicle.

NOTE:

The remote negative (-) post is located in the front of the engine compartment on the driver's side.

WHAT TO DO IN EMERGENCIES

WARNING!

Do not connect the jumper cable to the negative (-) post of the discharged battery. The resulting electrical spark could cause the battery to explode and could result in personal injury. Only use the specific ground point, do not use any other exposed metal parts.

5. Start the engine in the vehicle that has the booster battery. Let the engine idle a few minutes and then start the engine in the vehicle with the discharged battery.
6. Once the engine is started, disconnect the jumper cables in the reverse sequence:

Disconnecting The Jumper Cables

1. Disconnect the negative end (-) of the jumper cable from the remote negative (-) post of the vehicle with the discharged battery.
2. Disconnect the opposite end of the negative (-) jumper cable from the negative (-) post of the booster battery.
3. Disconnect the positive end (+) of the jumper cable from the positive (+) post of the booster battery.
4. Disconnect the opposite end of the positive (+) jumper cable from the remote positive (+) post of the discharged vehicle.
5. Close the cover of the Front Power Distribution Center.

If frequent jump-starting is required to start your vehicle you should have the battery and charging system inspected at your authorized dealer.

CAUTION!

Accessories plugged into the vehicle power outlets draw power from the vehicle's battery, even when not in use (i.e., cellular devices, etc.). Eventually, if plugged in long enough without engine operation, the vehicle's battery will discharge sufficiently to degrade battery life and/or prevent the engine from starting.

Battery Location

There are two remote jump starting posts under the hood which is the recommended jump start location. If access to the battery is needed, an access panel on the driver's side floor will allow for battery access.

WHAT TO DO IN EMERGENCIES

GEAR SELECTOR OVERRIDE

If a malfunction occurs and the gear selector cannot be moved out of the PARK position, you can use the following procedure to temporarily move the gear selector:

1. Turn the engine off.
2. Firmly apply the parking brake.
3. Using a small screwdriver or similar tool, remove the gear selector override access cover which is located below the gear selector.
4. Push and maintain firm pressure on the brake pedal.
5. Insert the screwdriver or similar tool into the access port, and push and hold the override release lever.
6. Move the gear selector to the NEUTRAL position.
7. The vehicle may then be started in NEUTRAL.
8. Reinstall the gear selector override access cover.

TOWING A DISABLED VEHICLE

This section describes procedures for towing a disabled vehicle using a commercial towing service.

Towing Condition	Wheels OFF the Ground	ALL Models
Flat Tow	NONE	If transmission is operable: <ul style="list-style-type: none">• Transmission in NEUTRAL• 25 mph (40 km/h) max speed• 15 miles (24 km) max distance
Wheel Lift or Dolly Tow	Rear	
	Front	OK
Flatbed	ALL	BEST METHOD

Proper towing or lifting equipment is required to prevent damage to your vehicle. Use only tow bars and other equipment designed for this purpose, following equipment manufacturer's instructions. Use of safety chains is mandatory. Attach a tow bar or other towing device to main structural members of the vehicle, not to bumpers or associated brackets. State and local laws regarding vehicles under tow must be observed.

If you must use the accessories (wipers, defrosters, etc.) while being towed, the ignition must be in the ON/RUN position.

WHAT TO DO IN EMERGENCIES

If the key fob is unavailable or the vehicle's battery is discharged, see “Gear Selector Override” in this section for instructions on shifting the automatic transmission out of PARK for towing.

CAUTION!

- Do not use sling type equipment when towing. Vehicle damage may occur.
- When securing the vehicle to a flat bed truck, do not attach to front or rear suspension components. Damage to your vehicle may result from improper towing.

Automatic Transmission

The manufacturer recommends towing your vehicle with all four wheels **OFF** the ground using a flatbed.

If flatbed equipment is not available, and the transmission is operable, this vehicle may be towed (with front wheels on the ground) under the following conditions:

- The transmission must be in NEUTRAL.
- The towing speed must not exceed 25 mph (40 km/h).
- The towing distance must not exceed 15 miles (24 km).

If the transmission is not operable, or the vehicle must be towed faster than 25 mph (40 km/h) or farther than 15 miles (24 km), tow with the front wheels **OFF** the ground (using a flatbed truck, or wheel lift equipment with the front wheels raised).

CAUTION!

- Towing faster than 25 mph (40 km/h) or farther than 15 miles (24 km) with front wheels on the ground can cause severe transmission damage. Damage from improper towing is not covered under the New Vehicle Limited Warranty.
- Towing this vehicle in violation of the above requirements can cause severe transmission damage. Damage from improper towing is not covered under the New Vehicle Limited Warranty.

FREING A STUCK VEHICLE

If your vehicle becomes stuck in mud, sand, or snow, it can often be moved using a rocking motion. Turn the steering wheel right and left to clear the area around the front wheels. Then shift back and forth between DRIVE and REVERSE , while gently pressing the accelerator. Use the least amount of accelerator pedal pressure that will maintain the rocking motion, without spinning the wheels or racing the engine.

NOTE:

Vehicles with diesel engine (automated manual transmission) cannot be rocked in this manner, because the transmission will not allow shifts between forward and REVERSE gears while the wheels are turning.

WHAT TO DO IN EMERGENCIES

CAUTION!

Racing the engine or spinning the wheels may lead to transmission overheating and failure. Allow the engine to idle with the transmission in NEUTRAL for at least one minute after every five rocking-motion cycles. This will minimize overheating and reduce the risk of transmission failure during prolonged efforts to free a stuck vehicle.

NOTE:

Push the "ESC Off" switch, to place the Electronic Stability Control (ESC) system in "Partial Off" mode, before rocking the vehicle. Refer to "Electronic Brake Control System" in "Starting And Operating" in the Owner's Manual on the DVD for further information. Once the vehicle has been freed, push the "ESC Off" switch again to restore "ESC On" mode.

CAUTION!

- When "rocking" a stuck vehicle by shifting between DRIVE and REVERSE, do not spin the wheels faster than 15 mph (24 km/h), or drivetrain damage may result.
- Revving the engine or spinning the wheels too fast may lead to transmission overheating and failure. It can also damage the tires. Do not spin the wheels above 30 mph (48 km/h) while in gear (no transmission shifting occurring).

WARNING!

Fast spinning tires can be dangerous. Forces generated by excessive wheel speeds may cause damage, or even failure, of the axle and tires. A tire could explode and injure someone. Do not spin your vehicle's wheels faster than 30 mph (48 km/h) or for longer than 30 seconds continuously without stopping when you are stuck. And do not let anyone near a spinning wheel, no matter what the speed.

ENHANCED ACCIDENT RESPONSE SYSTEM (EARS)

This vehicle is equipped with an Enhanced Accident Response System.

Please refer to "Supplemental Restraint System (SRS) — Air Bags" in "Getting Started" in this guide for further information on the Enhanced Accident Response System (EARS) function.

EVENT DATA RECORDER (EDR)

This vehicle is equipped with an event data recorder (EDR). The main purpose of an EDR is to record, in certain crash or near crash-like situations, such as an air bag deployment or hitting a road obstacle, data that will assist in understanding how a vehicle's systems performed.

Please refer to "Supplemental Restraint System (SRS) — Air Bags" in "Getting Started" in this guide for further information on the Event Data Recorder (EDR).

MAINTAINING YOUR VEHICLE

TO OPEN AND CLOSE THE HOOD

To open the hood, two latches must be released.

1. Open the drivers door to gain access to the hood release lever. Pull the hood release lever located on the side of the instrument panel.
2. Move to the outside of the vehicle, reach into the opening beneath the center of the hood and push the safety latch lever to the right to release it, before raising the hood.
3. Raise the hood and place the hood prop rod in hood slot to secure the hood in the open position.



Hood Release

CAUTION!

To prevent possible damage:

- Before closing hood, make sure the hood prop rod is fully seated into its storage retaining clips.
- Do not slam the hood to close it. Use a firm downward push at the center front edge of the hood to ensure that both latches engage. Never drive your vehicle unless the hood is fully closed, with both latches engaged.

WARNING!

Be sure the hood is fully latched before driving your vehicle. If the hood is not fully latched, it could open when the vehicle is in motion and block your vision. Failure to follow this warning could result in serious injury or death.

MAINTAINING YOUR VEHICLE

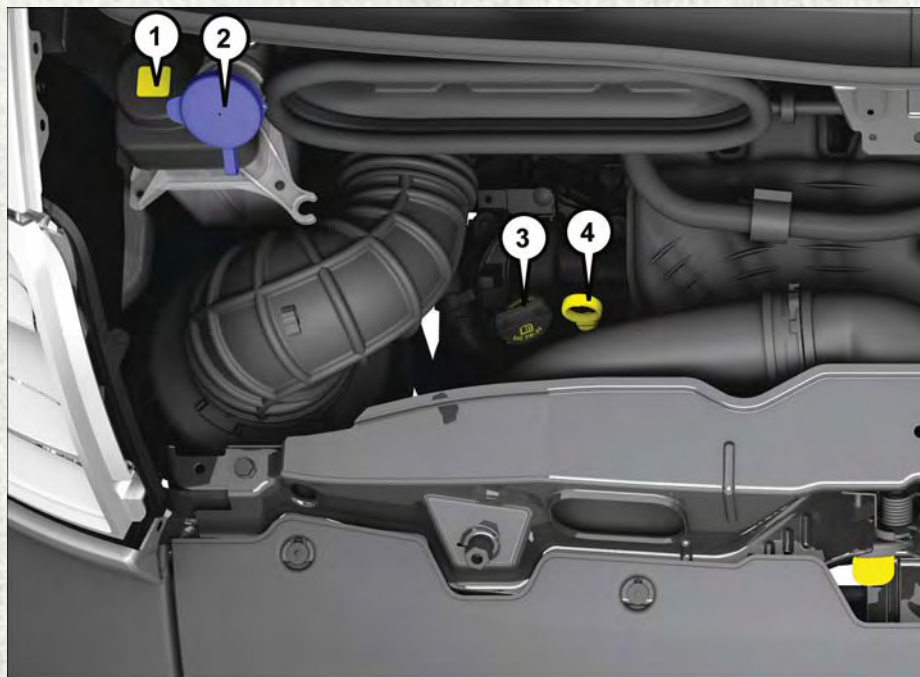

ENGINE COMPARTMENT — 3.6L

1. Power Steering Reservoir
2. Washer Fluid Reservoir
3. Engine Oil Fill
4. Engine Oil Dipstick

MAINTAINING YOUR VEHICLE

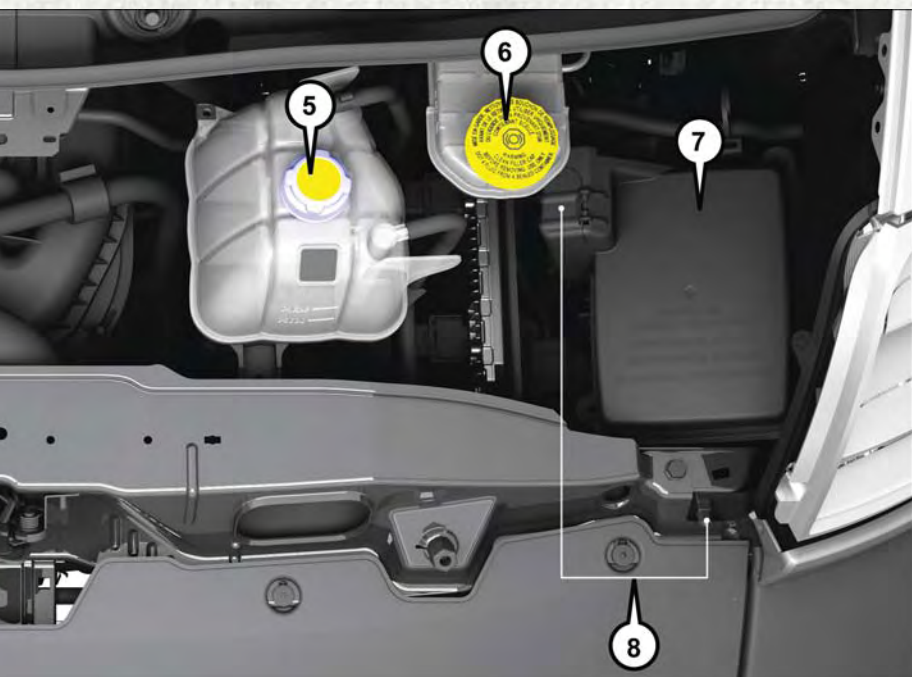

- 5. Engine Coolant Reservoir
- 6. Brake Fluid Reservoir
- 7. Power Distribution Center (Fuses)
- 8. Remote Jump Starting Points

MAINTAINING YOUR VEHICLE

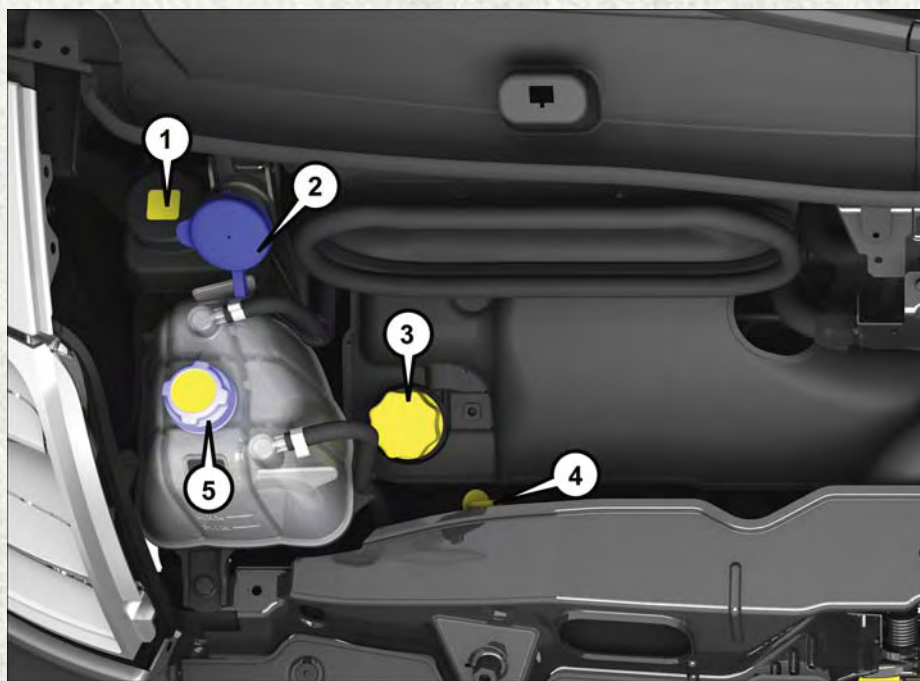

ENGINE COMPARTMENT — 3.0L DIESEL

1. Power Steering Reservoir
2. Washer Fluid Reservoir
3. Engine Oil Fill
4. Engine Oil Dipstick

MAINTAINING YOUR VEHICLE

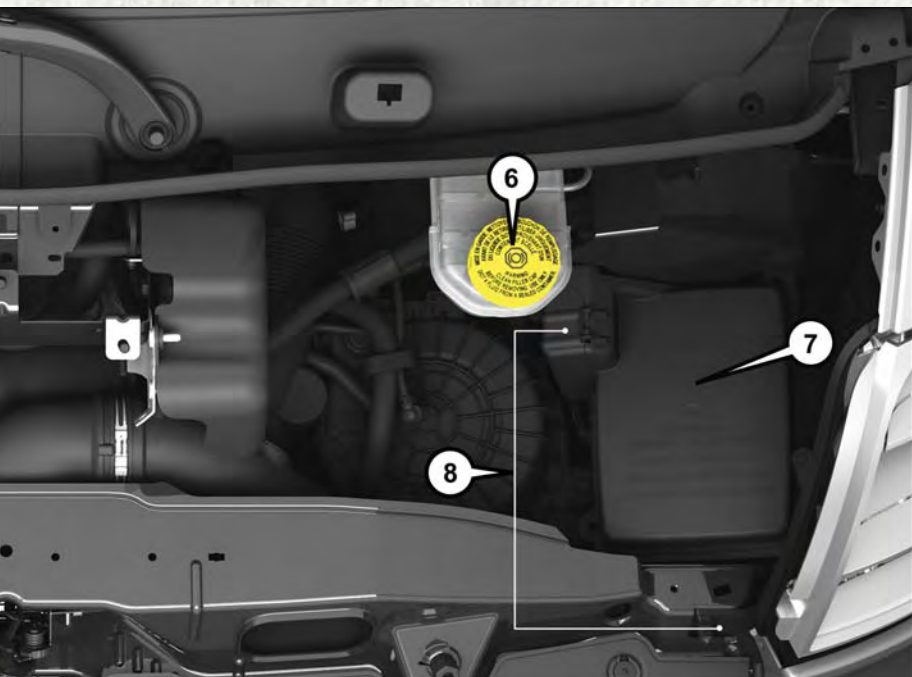

- 5. Engine Coolant Reservoir Cap
- 6. Brake Fluid Reservoir
- 7. Power Distribution Center (Fuses)
- 8. Remote Jump Starting Positive

MAINTAINING YOUR VEHICLE

FLUID CAPACITIES — GASOLINE ENGINE

	U.S.	Metric
Fuel (Approximate)	24 Gallons	90 Liters
Engine Oil with Filter		
3.6L Engine (SAE 5W-20, API Certified)	6 Quarts	5.6 Liters
Cooling System *		
3.6L Engine (MOPAR Antifreeze/Engine Coolant 10 Year/150,000 Mile Formula or equivalent)	10.5 Quarts	10 Liters

FLUIDS, LUBRICANTS AND GENUINE PARTS — GASOLINE ENGINE

Engine

Component	Fluid, Lubricant, or Genuine Part
Engine Coolant	We recommend you use MOPAR Antifreeze/Coolant 10 Year/150,000 Mile Formula OAT (Organic Additive Technology) meeting the requirements of FCA Material Standard MS.90032.
Engine Oil	We recommend you use API Certified SAE 5W-20 Engine Oil, meeting the requirements of FCA Material Standard MS-6395 such as MOPAR, Pennzoil, and Shell Helix. Refer to your engine oil filler cap for correct SAE grade.
Engine Oil Filter	We recommend you use MOPAR Engine Oil Filters.
Spark Plugs	We recommend you use MOPAR Spark Plugs.
Fuel Selection	87 Octane, 0-15% Ethanol.

CAUTION!

- Mixing of engine coolant (antifreeze) other than specified Organic Additive Technology (OAT) engine coolant (antifreeze), may result in engine damage and may decrease corrosion protection. Organic Additive Technology (OAT) engine coolant is different and should not be mixed with Hybrid Organic Additive Technology (HOAT) engine coolant (antifreeze) or any “globally compatible” coolant (antifreeze). If a non-OAT engine coolant (antifreeze) is introduced into the cooling system in an emergency, the cooling system will need to be drained, flushed, and refilled with fresh OAT coolant (conforming to MS.90032), by an authorized dealer as soon as possible.
- Do not use water alone or alcohol-based engine coolant (antifreeze) products. Do not use additional rust inhibitors or antirust products, as they may not be compatible with the radiator engine coolant and may plug the radiator.
- This vehicle has not been designed for use with propylene glycol-based engine coolant (antifreeze). Use of propylene glycol-based engine coolant (antifreeze) is not recommended.

MAINTAINING YOUR VEHICLE

Chassis

Component	Fluid, Lubricant, or Genuine Part
Automatic Transmission – 3.6L Gasoline Engine Only	Use Only ATF+4 Automatic Transmission Fluid. Failure to use ATF+4 fluid may affect the function or performance of your transmission. We recommend MOPAR ATF+4 Fluid.
Brake Master Cylinder	We recommend you use MOPAR DOT 4.
Power Steering Reservoir	Use Pentosin CHF 11S power steering fluid meeting FCA Material Standard MS-11655.

FLUID CAPACITIES — DIESEL ENGINE

	U.S.	Metric
Fuel (Approximate)		
3.0L Diesel Engine	24 Gallons	90 Liters
Diesel Exhaust Fluid Tank	5 Gallons	18.9 Liters
Engine Oil with Filter		
3.0L Diesel Engine	9.5 Quarts	9.0 Liters
Cooling System *		
3.0L Diesel Engine With MTA Transmission (MOPAR Antifreeze/Engine Coolant 10 Year/150,000 Mile Formula or equivalent)	12.7 Quarts	12 Liters
* Includes heater and coolant recovery bottle filled to MAX level. Add 2.9 Qts (2.8 L) if equipped with a rear heater.		

MAINTAINING YOUR VEHICLE

FLUIDS, LUBRICANTS AND GENUINE PARTS — DIESEL ENGINE

Engine

Component	Fluid, Lubricant, or Genuine Part
Engine Coolant	We recommend you use MOPAR Antifreeze/Coolant 10 Year/150,000 Mile Formula OAT (Organic Additive Technology).
Engine Oil	Only use ACEA C3 5W-30 Synthetic Low Ash engine oil meeting FCA Material Standard MS-11106 or Pennzoil Ultra Euro L full synthetic 5W-30 motor oil.
Engine Oil Filter	We recommend you use MOPAR Engine Oil Filters.
Fuel Filter	We recommend you use MOPAR Fuel Filter. Must meet 3 micron rating. Using a fuel filter that does not meet the manufacturers filtration and water separating requirements can severely impact fuel system life and reliability.
Fuel Selection	Use good quality diesel fuel from a reputable supplier in your vehicle. Federal law requires that you must fuel this vehicle with Ultra Low Sulfur Highway Diesel fuel (15 ppm Sulfur maximum) and prohibits the use of Low Sulfur Highway Diesel fuel (500 ppm Sulfur maximum) to avoid damage to the emissions control system. For most year-round service, No. 2 diesel fuel meeting ASTM specification D-975 Grade S15 will provide good performance. We recommend you use a blend of up to 5% biodiesel, meeting ASTM specification D-975 with your diesel engine. This vehicle is compatible with biodiesel blends greater than 5% but no greater than 20% biodiesel meeting ASTM specification D-7467 provided the shortened maintenance intervals are followed as directed.
Diesel Exhaust Fluid	MOPAR Diesel Exhaust Fluid (API Certified) (DEF) or equivalent that has been API Certified to the ISO 22241 standard. Use of fluids not API Certified to ISO 22241 may result in system damage.

NOTE:

If the vehicle is exposed to extreme cold (below 20°F or -7°C), or is required to operate at colder-than-normal conditions for prolonged periods, use climatized No. 2 diesel fuel or dilute the No. 2 diesel fuel with 50% No. 1 diesel fuel. This will provide better protection from fuel gelling or wax-plugging of the fuel filter.

MAINTAINING YOUR VEHICLE

CAUTION!

- Mixing of engine coolant (antifreeze) other than specified Organic Additive Technology (OAT) engine coolant (antifreeze), may result in engine damage and may decrease corrosion protection. Organic Additive Technology (OAT) engine coolant is different and should not be mixed with Hybrid Organic Additive Technology (HOAT) engine coolant (antifreeze) or any “globally compatible” coolant (antifreeze). If a non-OAT engine coolant (antifreeze) is introduced into the cooling system in an emergency, the cooling system will need to be drained, flushed, and refilled with fresh OAT coolant (conforming to MS.90032), by an authorized dealer as soon as possible.
- Do not use water alone or alcohol-based engine coolant (antifreeze) products. Do not use additional rust inhibitors or antirust products, as they may not be compatible with the radiator engine coolant and may plug the radiator.
- This vehicle has not been designed for use with propylene glycol-based engine coolant (antifreeze). Use of propylene glycol-based engine coolant (antifreeze) is not recommended.

Chassis

Component	Fluid, Lubricant, or Genuine Part
Automated Manual Transmission	<ul style="list-style-type: none">• Gearbox: Full synthetic 75W-85 manual transmission fluid meeting the API GL4 specification.• Control system: MOPAR C Series DDCT SAE 75W Hydraulic Fluid or equivalent.• Hydraulic Clutch Operating System: MOPAR Brake and Clutch Fluid DOT 4 Motor Vehicle or equivalent. Failure to use the correct fluid may affect the function or performance of your transmission.
Brake Master Cylinder	We recommend you use MOPAR DOT 4.
Power Steering Reservoir	Use Pentosin CHF 11S power steering fluid meeting FCA Material Standard MS-11655.

MAINTAINING YOUR VEHICLE

MAINTENANCE PROCEDURES

For information on the maintenance procedures for your vehicle, please refer to “Maintenance Procedures” in “Maintaining Your Vehicle” in your Owner’s Manual or applicable supplement on the DVD for further details.

MAINTENANCE SCHEDULE — GASOLINE ENGINE

Your vehicle is equipped with an automatic oil change indicator system. The oil change indicator system will remind you that it is time to take your vehicle in for scheduled maintenance.

Based on engine operation conditions, the oil change indicator message will illuminate in the instrument cluster. This means that service is required for your vehicle. Operating conditions such as frequent short-trips, trailer tow, and extremely hot or cold ambient temperatures will influence when the “Oil Change Required” message is displayed. Severe Operating Conditions can cause the change oil message to illuminate as early as 3,500 miles (5,600 km) since last reset. Have your vehicle serviced as soon as possible, within the next 500 miles (805 km).

Your authorized dealer will reset the oil change indicator message after completing the scheduled oil change. If a scheduled oil change is performed by someone other than your authorized dealer, the message can be reset by referring to the steps described under “Electronic Vehicle Information Center (EVIC)” in “Understanding Your Instrument Panel” in your owners manual on the DVD for further information.

NOTE:

Under no circumstances should oil change intervals exceed 10,000 miles (16,000 km), twelve months or 350 hours of engine run time, whichever comes first. The 350 hours of engine run or idle time is generally only a concern for fleet customers.

MAINTAINING YOUR VEHICLE

Severe Duty All Models

Change Engine Oil at 4,000 miles (6,500 km) if the vehicle is operated in a dusty and off road environment or is operated predominately at idle or only very low engine RPM's. This type of vehicle use is considered Severe Duty.

Once A Month Or Before A Long Trip:

- Check engine oil level
- Check windshield washer fluid level
- Check the tire inflation pressures and look for unusual wear or damage
- Check the fluid levels of the coolant reservoir, brake master cylinder, and power steering and fill as needed
- Check function of all interior and exterior lights

Required Maintenance Intervals

Refer to the maintenance schedules on the following page for the required maintenance intervals.

At Every Oil Change Interval As Indicated By Oil Change Indicator System:
• Change oil and filter.
• Rotate the tires. Rotate at the first sign of irregular wear, even if it occurs before the oil indicator system turns on.
• Inspect battery and clean and tighten terminals as required.
• Inspect brake pads, shoes, rotors, drums, hoses and park brake.
• Inspect engine cooling system protection and hoses.
• Inspect exhaust system.
• Inspect engine air cleaner if using in dusty or off-road conditions.

MAINTAINING YOUR VEHICLE

Maintenance Chart

Refer to the Maintenance Schedules on the following pages for the required maintenance intervals.

Mileage or time passed (whichever comes first)	20,000	30,000	40,000	50,000	60,000	70,000	80,000	90,000	100,000	110,000	120,000	130,000	140,000	150,000
Or Years:	2	3	4	5	6	7	8	9	10	11	12	13	14	15
Or Kilometers:	32,000	48,000	64,000	80,000	96,000	112,000	128,000	144,000	160,000	176,000	192,000	208,000	224,000	240,000
Additional Inspections														
Inspect the CV joints.		X			X			X			X			X
Inspect front suspension, tie rod ends, boot seals, and replace if necessary.	X		X		X		X		X		X		X	
Inspect the brake pads, replace as necessary.	X		X		X		X		X		X		X	
Additional Maintenance														
Replace engine air filter.		X			X			X			X			X
Replace cabin/air conditioning filter.	X		X		X		X		X		X		X	
Replace Brake Fluid every two years	X		X		X		X		X		X		X	
Replace spark plugs. **									X					
Flush and replace the engine coolant at 10 years or 150,000 miles (240,000 km) whichever comes first.									X					X
Change automatic transmission fluid and filter.					X									
Inspect and replace PCV valve if necessary.									X					

** The spark plug change interval is mileage based only, yearly intervals do not apply.

WARNING!

- You can be badly injured working on or around a motor vehicle. Do only service work for which you have the knowledge and the right equipment. If you have any doubt about your ability to perform a service job, take your vehicle to a competent mechanic.
- Failure to properly inspect and maintain your vehicle could result in a component malfunction and effect vehicle handling and performance. This could cause an accident.

MAINTAINING YOUR VEHICLE

MAINTENANCE RECORD

	Odometer	Date	Signature, Authorized Service Center
20,000 Miles (32,000 km) or 2 Years			
30,000 Miles (48,000 km) or 3 Years			
40,000 Miles (64,000 km) or 4 Years			
50,000 Miles (80,000 km) or 5 Years			
60,000 Miles (96,000 km) or 6 Years			
70,000 Miles (112,000 km) or 7 Years			
80,000 Miles (128,000 km) or 8 Years			

	Odometer	Date	Signature, Authorized Service Center
90,000 Miles (144,000 km) or 9 Years			
100,000 Miles (160,000 km) or 10 Years			
110,000 Miles (176,000 km) or 11 Years			
120,000 Miles (192,000 km) or 12 Years			
130,000 Miles (208,000 km) or 13 Years			
140,000 Miles (224,000 km) or 14 Years			
150,000 Miles (240,000 km) or 15 Years			

MAINTAINING YOUR VEHICLE

MAINTENANCE SCHEDULE — DIESEL ENGINE

Your vehicle is equipped with an automatic oil change indicator system. The oil change indicator system will remind you that it is time to take your vehicle in for scheduled maintenance.

Based on engine operation conditions, the oil change indicator message will illuminate in the instrument cluster. This means that service is required for your vehicle. Operating conditions such as frequent short-trips, trailer tow, and extremely hot or cold ambient temperatures will influence when the “Oil Change Required” message is displayed. Severe Operating Conditions can cause the change oil message to illuminate as early as 3,500 miles (5,600 km) since last reset. Have your vehicle serviced as soon as possible, within the next 500 miles (805 km).

Your authorized dealer will reset the oil change indicator message after completing the scheduled oil change. If a scheduled oil change is performed by someone other than your authorized dealer, the message can be reset by referring to the steps described under “Electronic Vehicle Information Center (EVIC)” in “Understanding Your Instrument Panel” in your Owners Manual on the DVD for further information.

NOTE:

Under no circumstances should oil change intervals exceed 18,500 miles (29,773 km) or twelve months, whichever comes first.

Once A Month Or Before A Long Trip:

- Check engine oil level
- Check windshield washer fluid level
- Check the tire inflation pressures and look for unusual wear or damage
- Check the fluid levels of the coolant reservoir, brake master cylinder, and power steering and fill as needed
- Check function of all interior and exterior lights

Required Maintenance Intervals.

Refer to the maintenance schedules on the following page for the required maintenance intervals.

At Every Oil Change Interval As Indicated By The Oil Change Indicator System:
• Change oil and filter.
• Rotate the tires. Rotate at the first sign of irregular wear, even if it occurs before your next scheduled service.
• Inspect battery and clean and tighten terminals as required.
• Inspect brake pads, rotors, hoses and park brake.
• Inspect engine cooling system protection and hoses.
• Inspect exhaust system.
• Inspect engine air cleaner if using in dusty or off-road conditions.

MAINTAINING YOUR VEHICLE

Maintenance Chart — Diesel Fuel Up To B5 Biodiesel

Mileage or time passed (whichever comes first)	1	2	3	4	5	6	7	8	9	10	11	12	13	14	15
	16,000	32,000	48,000	64,000	80,000	96,000	112,000	128,000	144,000	160,000	176,000	192,000	208,000	224,000	240,000
Or Years:	1	2	3	4	5	6	7	8	9	10	11	12	13	14	15
Or Kilometers:	16,000	32,000	48,000	64,000	80,000	96,000	112,000	128,000	144,000	160,000	176,000	192,000	208,000	224,000	240,000
Additional Inspections															
Completely fill the Diesel Exhaust Fluid tank.	X	X	X	X	X	X	X	X	X	X	X	X	X	X	X
Inspect the CV joints.		X				X				X		X			X
Inspect front suspension, tie rod ends, boot seals, and replace if necessary.		X		X		X		X		X		X		X	
Inspect the brake pads, replace as necessary.		X		X		X		X		X		X		X	
Check Transmission Actuation System Oil and Hydraulic Clutch Operating Oil		X				X			X			X			X
Additional Maintenance															
Replace fuel filter and drain water from fuel.		X				X			X			X			X
Replace engine air filter.		X				X			X			X			X
Replace cabin/air conditioning filter.		X		X		X		X		X		X		X	
Replace Brake Fluid every two years.*		X		X		X		X		X		X		X	
Replace Hydraulic Clutch Oil every two years or 60,000 miles (96,000 km) which ever comes first.		X		X		X		X		X		X		X	
Flush and replace the engine coolant at 10 years or 150,000 miles (240,000 km) whichever comes first.										X					X
Change FEAD Belt every four years or 80,000 miles (128,000 km) which ever comes first.			X					X				X			
Change Glow Plugs every five years or 150,000 miles (240,000 km) which ever comes first.					X										X
Change Automatic Belt tensioner every five years or 150,000 miles (240,000 km) which ever comes first.					X					X					X

* The brake fluid change interval is time based only. Mileage intervals do not apply.

NOTE:
Change Timing Chain and Gear at 249,000 miles (400,000 km).

WARNING!

- You can be badly injured working on or around a motor vehicle. Do only service work for which you have the knowledge and the right equipment. If you have any doubt about your ability to perform a service job, take your vehicle to a competent mechanic.
- Failure to properly inspect and maintain your vehicle could result in a component malfunction and effect vehicle handling and performance. This could cause an accident.

MAINTAINING YOUR VEHICLE

Additional Maintenance — B6 To B20 Biodiesel

NOTE:

- Under no circumstances should oil change intervals exceed 10,000 miles (16 093km) or six months, whichever comes first.
- The owner is required to monitor mileage for B6-B20 biodiesel, the automatic oil change indicator system does not reflect the use of biofuels.

Additional Maintenance Chart — B6 To B20 Biodiesel

Mileage or time passed (whichever comes first)	10,000	20,000	30,000	40,000	50,000	60,000	70,000	80,000	90,000	100,000	110,000	120,000	130,000	140,000	150,000
	1	2	3	4	5	6	7	8	9	10	11	12	13	14	15
Or Years:															
Or Kilometers:	16,000	32,000	48,000	64,000	80,000	96,000	112,000	128,000	144,000	160,000	176,000	192,000	208,000	224,000	240,000
Additional B6 to B20 Maintenance															
Replace fuel filter and drain water from the fuel filter assembly.		X		X		X		X		X		X		X	

WARNING!

- You can be badly injured working on or around a motor vehicle. Do only service work for which you have the knowledge and the right equipment. If you have any doubt about your ability to perform a service job, take your vehicle to a competent mechanic.
- Failure to properly inspect and maintain your vehicle could result in a component malfunction and effect vehicle handling and performance. This could cause an accident.

MAINTAINING YOUR VEHICLE

MAINTENANCE RECORD

	Odometer	Date	Signature, Authorized Service Center
20,000 Miles (32,000 km) or 2 Years			
30,000 Miles (48,000 km) or 3 Years			
40,000 Miles (64,000 km) or 4 Years			
50,000 Miles (80,000 km) or 5 Years			
60,000 Miles (96,000 km) or 6 Years			
70,000 Miles (112,000 km) or 7 Years			
80,000 Miles (128,000 km) or 8 Years			

	Odometer	Date	Signature, Authorized Service Center
90,000 Miles (144,000 km) or 9 Years			
100,000 Miles (160,000 km) or 10 Years			
110,000 Miles (176,000 km) or 11 Years			
120,000 Miles (192,000 km) or 12 Years			
130,000 Miles (208,000 km) or 13 Years			
140,000 Miles (224,000 km) or 14 Years			
150,000 Miles (240,000 km) or 15 Years			

MAINTAINING YOUR VEHICLE

FUSES

WARNING!

- When replacing a blown fuse, always use an appropriate replacement fuse with the same amp rating as the original fuse. Never replace a fuse with another fuse of higher amp rating. Never replace a blown fuse with metal wires or any other material. Failure to use proper fuses may result in serious personal injury, fire and/or property damage.
- Before replacing a fuse, make sure that the ignition is off and that all the other services are switched off and/or disengaged.
- If the replaced fuse blows again, contact an authorized dealer.
- If a general protection fuse for safety systems (air bag system, braking system), power unit systems (engine system, gearbox system) or steering system blows, contact an authorized dealer.

Underhood Fuses

The Front Power Distribution Center is located on the driver's side of the engine compartment. To access the fuses, remove the cover.

The ID number of the electrical component corresponding to each fuse can be found on the back of the cover.

Cavity	Maxi Fuse	Mini Fuse	Description
F01	40 Amp Orange	–	Electronic Stability Control (ESC) Pump
F02	20 Amp Yellow (3.6 Gasoline Engine)	–	Starter Relay 3.6L (3.6 Gasoline Engine)
F02	50 Amp Red (3.0 Diesel Engine)	–	Glow Plug Unit (3.0 Diesel Engine)
F04	50 Amp Red (3.6 Gasoline Engine)	–	Secondary Power Distribution Center (PDC) (Trans Power Relay, Vacuum Pump, KL30 for the Shifter Transmission Module [STM]) (3.6 Gasoline Engine)
F04	40 Amp Orange (3.0 Diesel Engine)	–	Fuel Filter Heater (3.0 Diesel Engine)
F05	30 Amp Green	–	SELESPEED Pump RELE (3.0 Diesel Engine) - If Equipped
F06	40 Amp Orange (non A/C) 60 Amp Blue (A/C)	–	Engine Cooling Fan - 2nd Speed

MAINTAINING YOUR VEHICLE

Cavity	Maxi Fuse	Mini Fuse	Description
F07	50 Amp Red (non A/C) 60 Amp Blue (A/C)	–	Engine Cooling Fan - 1st Speed
F08	40 Amp Orange	–	Passenger Compartment Blower
F09	–	15 Amp Blue	Rear Power Outlet
F10	–	15 Amp Blue	Horn
F11	–	15 Amp Blue	Fuel Pressure Regulator (MPROP)- DRV (3.0 Diesel Engine) — If Equipped
F14	–	20 Amp Yellow	Power Outlet
F15	–	7.5 Amp Brown	USB Charger
F16	–	7.5 Amp Brown	KL15 Shifter Transmission Module (STM) (3.6), KL15 Starter Relay Coil (3.6 Gasoline Engine)
F16	–	7.5 Amp Brown	KL15 Manual Transmission Automated (MTA), KL15 Gear Selector Unit, KL15 Engine Control Module (ECM), KL15 Starter Relay Coil (3.0 Diesel Engine)
F17	–	20 Amp Yellow	Engine Control Module (ECM), Injectors (3.6 Gasoline Engine)
F17	–	20 Amp Yellow	Secondary Loads, Engine Control Module (ECM) (3.0 Diesel Engine)
F18	–	7.5 Amp Brown	KL30 Engine Control Module (ECM), KL30 Main Relay Coil (3.6 Gasoline Engine)
F18	–	7.5 Amp Brown	KL30 Manual Transmission Automated (MTA), KL30 Engine Control Module (ECM), KL30 Main Relay Coil (3.0 Diesel Engine)
F19	–	7.5 Amp Brown	A/C Compressor (If Equipped)
F20	–	30 Amp Green	Windshield Wiper
F21	–	15 Amp Blue	Fuel Pump
F22	–	20 Amp Yellow	Engine Control Module (ECM), Ignition Coils (3.6 Gasoline Engine)
F22	–	20 Amp Yellow	Engine Control Module (ECM), Primary Loads (3.0 Diesel Engine)
F23	–	20 Amp Yellow	Electronic Stability Control (ESC) Valves
F24	–	7.5 Amp Brown	KL15 Vacuum pump relay coil (3.6 Gasoline Engine) — If Equipped
F30	–	15 Amp Blue	Heated Mirrors

MAINTAINING YOUR VEHICLE

Front PDC Additional Fuses

The additional fuse box is located inside the front PDC Box.

Cavity	Mini Fuse	Description
F61	20 Amp Yellow	Vacuum Pump (3.6 Gasoline Engine) — If Equipped
F62	30 Amp Green	Transmission Power RELE (3.6 Gasoline Engine) — If Equipped
F64	7.5 Amp Brown	Urea Pump (3.0 Diesel Engine) — If Equipped
F65	25 Amp White	Urea NOX Sensor 1–2 — PM Sensor (3.0 Diesel Engine) — If Equipped
F66	5 Amp Beige	Shifter Transmission Module (STM) (3.6 Gasoline Engine) — If Equipped

Interior Fuses

The interior fuse panel is part of the Body Control Module (BCM) and is located on the driver's side under the instrument panel.

Cavity	Mini Fuse	Description
F12	10 Amp Red	Right Low Beam
F13	10 Amp Red	Left Low Beam
F31	5 Amp Beige	INT/A
F32	10 Amp Red	SBMT
F34	7.5 Amp Brown	Clearance Lights
F36	15 Amp Blue	+30 (ACM – TPCU – RRM – DLC)
F37	5 Amp Beige	INT (BRAKE NO – IPC)
F38	15 Amp Blue	Central Locking
F42	5 Amp Beige	INT (BSM – SAS – BRAKE NC)
F43	20 Amp Yellow	Bi-Directional Washer Pump
F47	20 Amp Yellow	Driver Power Window
F48	20 Amp Yellow	Passenger Power Window
F49	5 Amp Beige	INT (PAM – CCS – RRM – ECM)
F50	7.5 Amp Brown	INT (ORC)
F51	5 Amp Beige	INT (REAR CAMERA-AUX)
F53	5 Amp Beige	+30 (IPC)
F90	7.5 Amp Brown	Left High Beam
F91	7.5 Amp Brown	Right High Beam
F92	7.5 Amp Brown	Left Fog Lamp
F93	7.5 Amp Brown	Right Fog Lamp

MAINTAINING YOUR VEHICLE

Right Central Pillar Fuses

The right central pillar fuse panel is located on the interior side at the base of the passenger side B pillar.

Cavity	Mini Fuse	Description
F81	7.5 Amp Brown	Seat Heater
F83	20 Amp Yellow	Rear Left Windows Heater
F84	20 Amp Yellow	Rear Right Windows Heater
F86	20 Amp Yellow	Auxiliary Switch (From Battery) – If Equipped
F87	20 Amp Yellow	Auxiliary Switch (From Ignition) – If Equipped

TIRES — GENERAL INFORMATION

Tire Pressures

Check the inflation pressure of each tire, including the spare tire (if equipped), at least monthly and inflate to the recommended pressure for your vehicle.

The tire pressures recommended for your vehicle are found on the “Tire and Loading Information” label located on the driver’s side door opening or B-Pillar.

NOTE:

Refer to the Owner’s Manual on the DVD or the Tire Information Supplement located in your Owner’s Information kit for more information regarding tire warnings and instructions.



Tire And Loading Information Location
(Example)

MAINTAINING YOUR VEHICLE

WARNING!

- Overloading of your tires is dangerous. Overloading can cause tire failure, affect vehicle handling, and increase your stopping distance. Use tires of the recommended load capacity for your vehicle. Never overload them.
- Improperly inflated tires are dangerous and can cause collisions. Under-inflation increases tire flexing and can result in over-heating and tire failure. Over-inflation reduces a tire's ability to cushion shock. Objects on the road and chuck holes can cause damage that results in tire failure. Unequal tire pressures can cause steering problems. You could lose control of your vehicle. Over-inflated or under-inflated tires can affect vehicle handling and can fail suddenly, resulting in loss of vehicle control. Always drive with each tire inflated to the recommended cold tire inflation pressure.

SPARE TIRES — IF EQUIPPED

NOTE:

For vehicles equipped with Tire Service Kit instead of a spare tire, please refer to “Tire Service Kit” in “What To Do In Emergencies” on your DVD for further information.

CAUTION!

Because of the reduced ground clearance, do not take your vehicle through an automatic car wash with a compact or limited-use temporary spare installed. Damage to the vehicle may result.

Spare Tire Matching Original Equipped Tire And Wheel — If Equipped

Your vehicle may be equipped with a spare tire and wheel equivalent in look and function to the original equipment tire and wheel found on the front or rear axle of your vehicle. This spare tire may be used in the tire rotation for your vehicle. If your vehicle has this option, refer to an authorized tire dealer for the recommended tire rotation pattern.

Compact Spare Tire — If Equipped

The compact spare is for temporary emergency use only. You can identify if your vehicle is equipped with a compact spare by looking at the spare tire description on the Tire and Loading Information Placard located on the driver's side door opening or on the sidewall of the tire. Compact spare tire descriptions begin with the letter “T” or “S” preceding the size designation. Example: T145/80D18 103M.

T, S = Temporary Spare Tire

Since this tire has limited tread life, the original equipment tire should be repaired (or replaced) and reinstalled on your vehicle at the first opportunity.

MAINTAINING YOUR VEHICLE

Do not install a wheel cover or attempt to mount a conventional tire on the compact spare wheel, since the wheel is designed specifically for the compact spare tire. Do not install more than one compact spare tire and wheel on the vehicle at any given time.

WARNING!

Compact spares are for temporary emergency use only. With these spares, do not drive more than 50 mph (80 km/h). Temporary use spares have limited tread life. When the tread is worn to the tread wear indicators, the temporary use spare tire needs to be replaced. Be sure to follow the warnings, which apply to your spare. Failure to do so could result in spare tire failure and loss of vehicle control.

Full Size Spare — If Equipped

The full size spare is for temporary emergency use only. This tire may look like the originally equipped tire on the front or rear axle of your vehicle, but it is not. This spare tire may have limited tread life. When the tread is worn to the tread wear indicators, the temporary use full size spare tire needs to be replaced. Since it is not the same as your original equipment tire, replace (or repair) the original equipment tire and reinstall on the vehicle at the first opportunity.

Limited Use Spare — If Equipped

The limited-use spare tire is for temporary emergency use only. This tire is identified by a label located on the limited-use spare wheel. This label contains the driving limitations for this spare. This tire may look like the original equipped tire on the front or rear axle of your vehicle, but it is not. Installation of this limited-use spare tire affects vehicle handling. Since it is not the same as your original equipment tire, replace (or repair) the original equipment tire and reinstall on the vehicle at the first opportunity.

WARNING!

Limited-use spares are for emergency use only. Installation of this limited-use spare tire affects vehicle handling. With this tire, do not drive more than the speed listed on the limit-use spare wheel. Keep inflated to the cold tire inflation pressures listed on your Tire and Loading Information Placard located on the driver's side B-Pillar or the rear edge of the driver's side door. Replace (or repair) the original equipment tire at the first opportunity and reinstall it on your vehicle. Failure to do so could result in loss of vehicle control.

MAINTAINING YOUR VEHICLE

Wheel And Wheel Trim Care

All wheels and wheel trim, especially aluminum and chrome plated wheels, should be cleaned regularly with a mild soap and water to prevent corrosion.

To remove heavy soil and/or excessive brake dust, use MOPAR Wheel Cleaner or equivalent or select a non-abrasive, non-acidic cleaner.

CAUTION!

Do not use scouring pads, steel wool, a bristle brush, or metal polishes. Do not use oven cleaner. These products may damage the wheel's protective finish. Avoid automatic car washes that use acidic solutions or harsh brushes that may damage the wheel's protective finish. Only MOPAR Wheel Cleaner or equivalent is recommended.

REPLACEMENT BULBS

Interior Bulbs

	Bulb Number
Overhead Lamp	C5W
Sun Visors	C5W
Courtesy Lamp	FF500
Glove Compartment	C5W
Rear Courtesy Lamp	C5W

Exterior Bulbs

	Bulb Number
Front Low and High Beam Headlamp	H7LL
Front Park/Turn Signal Lamps	7444NA
Daytime Running Lamps (If Equipped)	7440
Front Side Marker Lamps	WY5W
Rear Tail/Stop Lamps	7443
Rear Turn Signal Lamps	7440NA
Rear Backup Lamps	921
Rear Side Marker Lamps	W3W
Front Fog Lamps	H11
License Plate Lamps	C5W
Front Roof Lamps	WY5W
Rear Roof Lamps	W3W

NOTE:

- Numbers refer to commercial bulb types that can be purchased from your authorized dealer.
- If a bulb needs to be replaced, visit your authorized dealer.

CUSTOMER ASSISTANCE

FCA US LLC CUSTOMER CENTER

P.O. Box 21-8004 Auburn Hills, MI 48321-8004 Phone: 1-866-726-4636

FCA CANADA INC. CUSTOMER CENTER

P.O. Box 1621 Windsor, Ontario N9A 4H6 Phone: 1-800-465-2001 (English)
Phone: 1-800-387-9983 (French)

ASSISTANCE FOR THE HEARING IMPAIRED

To assist customers who have hearing difficulties, the manufacturer has installed special TDD (Telecommunication Devices for the Deaf) equipment at its customer center. Any hearing or speech impaired customer, who has access to a TDD or a conventional teletypewriter (TTY) in the United States, can communicate with the manufacturer by dialing 1-800-380-CHRY. Canadian residents with hearing difficulties that require assistance can use the special needs relay service offered by Bell Canada. For TTY teletypewriter users, dial 711 and for Voice callers, dial 1-800-855-0511 to connect with a Bell Relay Service operator.

WARNING!

Engine exhaust, some of its constituents, and certain vehicle components contain, or emit, chemicals known to the State of California to cause cancer and birth defects, or other reproductive harm. In addition, certain fluids contained in vehicles and certain products of component wear contain, or emit, chemicals known to the State of California to cause cancer and birth defects, or other reproductive harm.

PUBLICATIONS ORDERING

- If you are the first registered retail owner of your vehicle, you may obtain a complimentary printed copy of the Owner's Manual, Navigation/Uconnect Manuals or Warranty Booklet. United States customers may visit the Ram Truck Contact Us page at www.ramtrucks.com scroll to the bottom of the page and select the "Contact Us" link, then select the "Owner's Manual and Glove Compartment Material" from the left menu. You may also obtain a complimentary copy by calling 1-866-726-4636 (U.S.) or 1-800-387-1143 (Canada).

CUSTOMER ASSISTANCE

- Replacement User Guide kits or DVDs or, if you prefer, additional printed copies of the Owner's Manual, Warranty Booklet or Radio Manuals may be purchased by visiting www.techauthority.com or by calling 1-800-890-4038 (U.S.) or 1-800-387-1143 (Canada). Visa, Master Card, American Express and Discover orders are accepted. If you prefer mailing your order, please call the above numbers for an order form.

NOTE:

- A street address is required when ordering manuals (no P.O. Boxes).
- The Owner's Manual and User Guide electronic files are also available on the Chrysler, Jeep®, Ram Truck, Dodge and SRT websites.
- Click on the "Owners" tab, select "Owner And Service Manuals", then select your desired model year and vehicle from the drop down lists.

REPORTING SAFETY DEFECTS IN THE UNITED STATES

If you believe that your vehicle has a defect that could cause a collision or cause injury or death, you should immediately inform the National Highway Traffic Safety Administration (NHTSA) in addition to notifying the manufacturer.

If NHTSA receives similar complaints, it may open an investigation, and if it finds that a safety defect exists in a group of vehicles, it may order a recall and remedy campaign. However, NHTSA cannot become involved in individual problems between you, your authorized dealer and the manufacturer.

To contact NHTSA, you may either call the Auto Safety Hotline toll free at 1-888-327-4236 (TTY: 1-800-424-9153), or go to <http://www.safercar.gov>; or write to: Administrator, NHTSA, 1200 New Jersey Avenue, SE., West Building, Washington, D.C. 20590. You can also obtain other information about motor vehicle safety from <http://www.safercar.gov>.

In Canada

If you believe that your vehicle has a safety defect, you should contact the Customer Service Department immediately. Canadian customers who wish to report a safety defect to the Canadian government should contact Transport Canada, Motor Vehicle Defect Investigations and Recalls at 1-800-333-0510 or go to <http://www.tc.gc.ca/roadsafety/>.

French Canadian customers who wish to report a safety defect to the Canadian government should contact Transport Canada, Motor Vehicle Defect Investigations and Recalls at 1-800-333-0510 or go to <http://www.tc.gc.ca/securiteroutiere/>.

AUTHENTIC ACCESSORIES BY MOPAR

In choosing Authentic Accessories you gain far more than expressive style, premium protection, or extreme entertainment, you also benefit from enhancing your vehicle with accessories that have been thoroughly tested and factory-approved.

The following highlights just some of the many Authentic Ram Accessories by MOPAR featuring a fit, finish, and functionality specifically for your Ram Promaster:

EXTERIOR:

- Splash Guards
- Hitch Receiver
- Side Window Air Deflectors
- 7/4 Way Trailer Tow Wiring Harness

INTERIOR:

- B-Pillar Grab Handle
- D-Pillar Grab Handle
- All-Weather Floor Mats
- Premium Carpet Floor Mats
- Cargo Compartment Floor Liner
- DOT Certified Emergency Roadside Kit

ELECTRONICS:

- Fog Lights
- Remote Start
- Back Up Camera
- Hands Free Bluetooth
- MOPAR Connect (WiFi)
- Cargo Compartment LED Lighting
- Electronic Vehicle Tracking System

For the full line of Authentic Ram Accessories by Mopar, visit your local dealership or online at mopar.com for U.S. residents and mopar.ca for Canadian residents.

NOTE:

All parts are subject to availability.

FREQUENTLY ASKED QUESTIONS

GETTING STARTED

Where are the controls for the Heated Seats? pg. 22

How to adjust your seat? pg. 17

ELECTRONICS

Which radio is in my vehicle?

- Uconnect RH3 pg. 40
- Uconnect 5.0 pg. 42

How do I activate the Audio Jack?

- Uconnect RH3 pg. 41
- Uconnect 5.0 pg. 46

How do I set the clock on my radio?

- Uconnect RH3 pg. 40
- Uconnect 5.0 pg. 43

How do I pair my cell phone via Bluetooth with the Uconnect Hands-Free Voice Activation System? pg. 54

How to use the power outlet? pg. 64

UTILITY

How do I know how much I can tow with my Ram ProMaster? pg. 66

WHAT TO DO IN EMERGENCIES

What do I do if my TPMS warning light is blinking? pg. 81

How do I change a flat tire? pg. 87

How do I Jump-Start my vehicle? pg. 102

MAINTAINING YOUR VEHICLE

Where is my Fuse Block located? pg. 128

What type of oil do I use 3.6L gasoline engine? pg. 114

What type of oil do I use 3.0L diesel engine? pg. 115

How often should I change my engine's oil? pg. 118

What should my tire pressure be set at? pg. 131

- Adding Diesel Exhaust Fluid76
- Adding Engine Coolant (Antifreeze)118
- Adding Fuel76
- Adding Washer Fluid118
- Air Bag
 - Advanced Front Air Bag10
 - Advance Front Air Bag9
 - Air Bag Components9
 - Air Bags9
 - Air Bag Warning Light9, 13
 - Enhanced Accident Response . .108
 - Event Data Recorder (EDR)14, 108
 - Front Air Bag9
 - Rollover9
 - Side Impacts9
- Air Bag Light13, 81
- Air Cleaner, Engine (Engine Air Cleaner Filter)118
- Air Conditioner Maintenance . . .118
- Air Conditioning25
- Air Conditioning Refrigerant . . .118
- Air Conditioning System118
- Alarm (Security Alarm)85
- Antifreeze (Engine Coolant)114, 115, 118
 - Disposal118
- Anti-Lock Warning Light81
- Appearance Care118
- Assistance Towing80
- Audio Jack41
- Automated Manual Transmission . .70
 - Fluid Type117
- Automatic Transmission
 - Fluid Type115
- Back-Up Camera35
- Battery118
- Body Mechanism Lubrication . . .118
- Brake Fluid115, 117
- Brakes118
- Brake System118
 - Master Cylinder118
 - Warning Light83
- Break-In Recommendations, Diesel68
- Break-In Recommendations, New Vehicle24
- Bulb Replacement134
- Bulbs, Light134
- Canada136
- Capacities, Fluid114, 115
- Caps, Filler
 - Fuel76
 - Oil (Engine)118
- Cargo Light28
- Car Washes118
- CD (Compact Disc) Player45
- Charging System Light80
- Child Restraints14
- Child Seat Installation14
- Cleaning
 - Wheels118
 - Windshield Wiper Blades118
- Clock40
- Clock Setting43
- Cluster Warning/Indicator Lights
 - Anti-Lock Brake (ABS) Light . . .81
 - Brake Warning Light83
 - Charging System Light80
 - Electronic Speed Control SET Indicator85
 - Electronic Throttle Control (ETC) Indicator Light81
 - Engine Temperature Warning Light80
 - Front Fog Light Indicator84
 - High Beam Indicator84
 - Malfunction Indicator Light (MIL)84
 - Oil Pressure Warning Light80
 - Park/Headlight ON Indicator . . .84
 - Tire Pressure Monitoring System (TPMS) Light81
 - Turn Signal Indicator84
 - Vehicle Security Light85
- Clutch118
- Clutch Fluid118
- Compact Spare Tire132
- Cooling System118
 - Adding Coolant (Antifreeze) . .118
 - Coolant Capacity114, 115

INDEX

- Coolant Level118
- Disposal Of Used Coolant118
- Drain, Flush, And Refill118
- Inspection118
- Points To Remember118
- Pressure Cap118
- Selection Of Coolant
(Antifreeze) . .114, 115, 116, 118
- Corrosion Protection118
- Customer Assistance135, 136
- Customer Programmable Features . .64

- DEF (Diesel Exhaust Fluid)77
- Defects, Reporting136
- Defroster, Rear Window25
- Diesel Exhaust Fluid
(DEF)76, 77, 116
- Diesel Fuel76, 116
- Diesel Fuel Requirements116
- Dimmer Control28
- Dimmer Switch, Headlight26
- Disabled Vehicle Towing80, 106
- Disposal
Antifreeze (Engine Coolant) . . .118

- Electronics
Your Vehicle's Sound System . . .36
- Electronic Speed Control (Cruise
Control)31
- Electronic Throttle Control Warning
Light81
- Electronic Vehicle Information Center
(EVIC)63
- Emergencies, What To Do In80
- Emergency80
- Emergency, In Case Of
Freeing Vehicle When Stuck . .107
- Jump Starting102
- Overheating86
- Towing80
- Engine68
- Air Cleaner118
- Block Heater70
- Break-In Recommendations . . .24
- Checking Oil Level118
- Coolant (Antifreeze)114, 116
- Cooling118
- Fuel Requirements114, 115
- Jump Starting102
- Oil114, 115, 116, 118
- Oil Filler Cap118
- Oil Selection114, 115, 118
- Overheating86
- Temperature Warning Light80
- Enhanced Accident Response
Feature108
- Exhaust Regeneration74
- Exhaust System118
- Exterior Lighting26

- FAQ138
- Filters
Air Cleaner118
- Engine Oil114, 116, 118
- Engine Oil Disposal118
- Flashers
Turn Signal84
- Fluid Capacities114, 115
- Fluids, Lubricants And Genuine
Parts114, 116
- Fog Lights84
- Freeing A Stuck Vehicle107
- Frequently Asked Questions138
- Fuel
Diesel116
- Filter116
- Octane Rating114
- Requirements114, 115
- Tank Capacity114, 115
- Fuses128

- General Maintenance118
- Glass Cleaning118

- Hands-Free Phone (Uconnect)54
- Headlights
Cleaning118
- High Beam26
- High Beam/Low Beam Select
Switch26
- Switch26
- Head Restraints16
- Heated Mirrors25
- Heated Seats22
- High Beam Indicator84

- High Beam/Low Beam Select
 (Dimmer) Switch26
- Hood Release109
- Instrument Cluster Indicator
 Lights84
- Instrument Cluster Warning Lights .80
- Instrument Panel Cover118
- Instrument Panel Lens Cleaning .118
- Interior And Instrument Lights .5, 27
- Interior Appearance Care.118
- Interior Lighting27
- Intermittent Wipers (Delay Wipers).29
- Introduction2
- iPod/USB/MP3 Control
 Bluetooth Streaming Audio54
- Jump Starting102
- Key Fob8
- Lane Change Assist27
- Lap/Shoulder Belts.8
- Light Bulbs134
- Lights
 Air Bag13
 Dimmer Switch, Headlight26
 Fog84
 Headlights26
 High Beam26
 High Beam Indicator84
 Low Fuel80
 Park27
 Seat Belt Reminder83
 Security Alarm85
 Tire Pressure Monitoring
 (TPMS)81
 Turn Signal26
- Lubrication, Body.118
- Maintenance Free Battery118
- Maintenance, General118
- Maintenance Procedures.118
- Maintenance Record.122, 127
- Maintenance Schedule . . .118, 123
- Malfunction Indicator Light
 (Check Engine)84
- Master Cylinder (Brakes).118
- Media Center Radio51
- Message Center
 Water In Fuel70
- Multi-Function Control Lever26
- Navigation.47
- New Vehicle Break-In Period . .24, 68
- Oil, Engine114, 116, 118
 Capacity114, 115
 Change Interval118
 Checking118
 Disposal118
 Filter114, 116, 118
 Filter Disposal118
 Materials Added To118
 Recommendation . .114, 115, 118
 Viscosity114, 115, 118
- Oil Filter, Selection.118
- Oil Pressure Light80
- Outlet
 Power64
- Overheating, Engine86
- Paint Care118
- ParkSense System, Rear.34
- Phone, Hands-Free (Uconnect). . .54
- Phone (Pairing).55
- Phone (Uconnect)54
- Placard, Tire And Loading
 Information.131
- Power
 Outlet (Auxiliary Electrical
 Outlet)64
- Power Steering Fluid.115, 117
- Programmable Electronic Features .64
- Radio42, 50
 Presets41, 44
- Radio Operation44
- Radio (Sound Systems).40, 50
- Rear Camera35
- Rear ParkSense System34
- Recreational Towing66
- Refrigerant.118
- Replacement Bulbs.134
- Reporting Safety Defects.136

INDEX

- Restraint, Head16
- Schedule, Maintenance118, 123
- Seat Belt
 - Seat Belt Pretensioner9
- Seat Belt Maintenance118
- Seat Belts8
 - Adjustable Shoulder Belt8
 - Pretensioners8
 - Reminder83
- Seats17
 - Heated22
- Security Alarm85
- Selection Of Coolant
 - (Antifreeze)114, 116
- Shift Lever Override106
- Signals, Turn84
- Sirius Satellite Radio45
- Spare Tire132, 133
- Spark Plugs114
- Speed Control
 - Accel/Decel34
- Speed Control (Cruise Control)31
- Starting
 - Cold Weather69
 - Engine Block Heater70
- Starting Procedures
 - (Diesel Engines)68
- Steering
 - Column Lock23
- Steering Wheel Audio Controls63
- Supplemental Restraint System - Air Bag9
- Telescoping Steering Column23
- Text Messaging59, 60
- Tires131, 132
 - Air Pressure131
 - Compact Spare132
 - General Information131, 132
 - Spare Tire132, 133
- Towing66, 106
 - Disabled Vehicle106
 - Recreational66
- Trailer Towing
 - Trailer And Tongue Weight66
- Trailer Weight66
- Transmission
 - Fluid115, 117, 118
 - Maintenance118
- Turbo Cool Down76
- Turn Signals84
- Uconnect (Hands-Free Phone)
 - Making A Phone Call54
 - Receiving A Call54
- Uconnect Phone54, 58, 59
- Uconnect Voice
 - Command47, 50, 51, 58
- USB Port41
- Voice Command47, 50, 51, 58
- Voice Recognition System
 - (VR)47, 50, 51, 58
- Washer
 - Adding Fluid118
- Washing Vehicle118
- Water in Fuel70
- Wheel And Wheel Trim118
- Wheel And Wheel Trim Care . .118, 134
- Windshield Washers29
 - Fluid29, 85
- Windshield Wiper Blades118
- Windshield Wipers29
- Wiper Blade Replacement118
- Wipers, Intermittent29

RAM PROMASTER

2016 USER GUIDE

This guide has been prepared to help you get quickly acquainted with your new Ram vehicle and to provide a convenient reference source for common questions. However, it is not a substitute for your Owner's Manual.

For complete operational instructions, maintenance procedures and important safety messages, please consult your Owner's Manual, Navigation/Uconnect Manuals and other Warning Labels in your vehicle.

Not all features shown in this guide may apply to your vehicle. For additional information on accessories to help personalize your vehicle, visit www.mopar.com (U.S.), www.mopar.ca (Canada) or your local RAM dealer.

DRIVING AND ALCOHOL

Drunken driving is one of the most frequent causes of collisions. Your driving ability can be seriously impaired with blood alcohol levels far below the legal minimum. If you are drinking, don't drive. Ride with a designated non-drinking driver, call a cab, a friend, or use public transportation.

WARNING

Driving after drinking can lead to a collision. Your perceptions are less sharp, your reflexes are slower, and your judgment is impaired when you have been drinking. Never drink and then drive.



GUTS-GLORY  **RAM**

DOWNLOAD A FREE ELECTRONIC COPY

OF THE OWNER'S MANUAL AND WARRANTY BOOKLET BY VISITING:

WWW.RAMTRUCKS.COM/EN/OWNERS/MANUALS OR WWW.RAMTRUCKS.COM/EN/WARRANTY (U.S.);
WWW.OWNERS.MOPAR.CA/EN (CANADA).

© 2015 FCA US LLC. ALL RIGHTS RESERVED. RAM IS A REGISTERED TRADEMARK OF FCA US LLC.



16VF-926-AA · RAM PROMASTER · THIRD EDITION · USER GUIDE